

Thorburn Flex Inc

Flexible Piping Specialist

HYDRAULIC HOSES & COUPLINGS

1st Edition

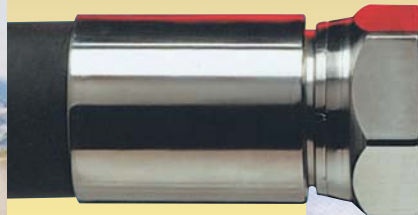

NOW AVAILABLE
STAINLESS
STEEL 316
HOSE
COUPLINGS

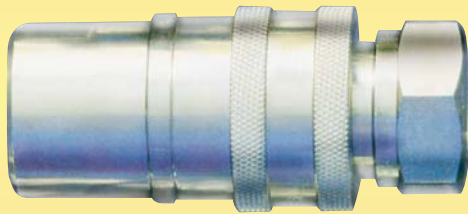

QUICK COUPLINGS

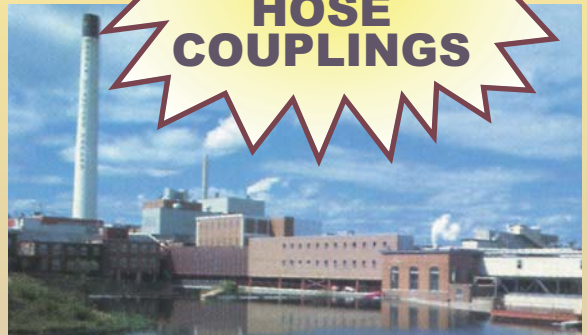
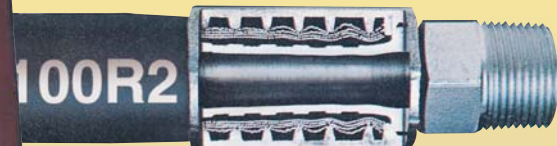

THORBURN SAE100R2



*For all your
Hydraulic
needs!*

Thorburn Flex Inc
Flexible Piping Specialist

173 Oneida Drive, Pointe-Claire,
Quebec, Canada H9R 1A9
Tel.: (514) 695-8710 Fax: (514) 695-8716

TOLL-FREE 1-800-363-6613

SAE100R13

5000 PSI

SAE100R13

100R2

Thorburn's Innovative Hydraulic Connector Technology



THORBURN offers unmatched capabilities and expertise in applications engineering, design, development and manufacturing of flexible piping systems. Operating under a strategy of global presence

in niche markets, the business is structured to consistently meet and exceed customer expectations of quality and value. Targeting Thorburn's resources allows its core technology to be leveraged and maximized into hundreds of demanding applications.



Shown is Jack Thorburn, who founded the company in 1954, enjoying one of his passions, sailing. Unfortunately, Jack passed away on February 16th, 1995. He will be sorely missed. The company's leadership passed on to Jack's eldest son, Robert, in September 1994.

- Inhouse design, manufacturing and testing capabilities



SAE100R12

- 316SS Hydraulic Hose Couplings for SAE100R2, SAE100R12, SAE100R13

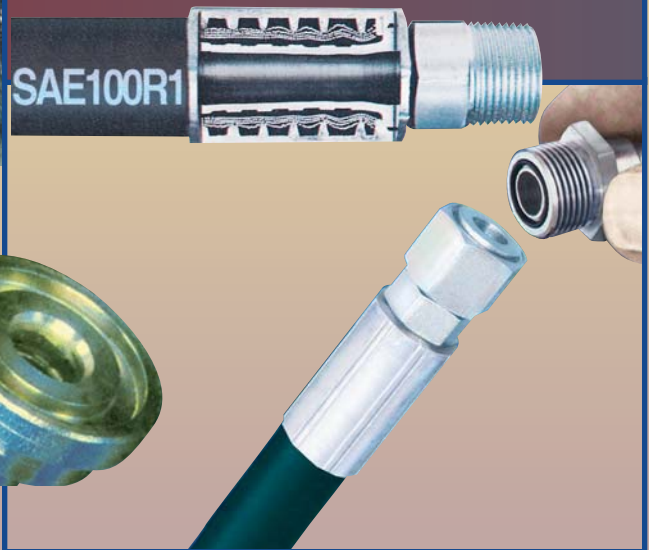

SAE100R1



Spécialiste en tuyaux flexibles

THORBURN

The Best of Both Worlds



EMPLOYEES

Thorburn people are the key factor in bringing together its technological, engineering, manufacturing, quality assurance and administrative resources to provide our customers with total satisfaction.

Our employees, representing over twenty nationalities have turned Thorburn into a lean manufacturing company. We are flexible, ready to respond instantly to customer needs with products and services unique in our industry.



THE HEART & SOUL OF THE COMPANY

Our people have turned Thorburn into a lean manufacturing company. We are flexible, ready to respond instantly to customer needs with products and services unique in our industry.

Through our combined efforts, we have designed systems for administration, engineering and manufacturing, based on our experience and knowledge gained from each customer and application.



CANDU BUSINESS UNIT

THORBURN offers unmatched capabilities and expertise in applications engineering, design development and manufacture of non-metallic and metallic flexible piping systems for Candu nuclear power plants. Operating under a strategy of global presence, Thorburn has developed a Candu business unit to service this niche market sector. Thorburn's nuclear components consistently meet and exceed all the quality design requirements of our Candu nuclear reactor business partners.



TOTAL CUSTOMER SATISFACTION

Our company may be known by its products but Thorburn knows that its products are the result of people whose combined competences build value, work towards excellence and keep the customer satisfied. Thorburn people are the key factor in bringing together its technological, engineering, manufacturing, quality assurance and administrative resources to provide the customer with total satisfaction.



QUALITY POLICY

Quality Assurance is a company culture at Thorburn which has been developed by a comprehensive Quality Management System; it requires the dedication, involvement and motivation of Thorburn's personnel at all levels of operation to ensure customer satisfaction and facilitate the continuous improvement process.



Table of Contents

Technical Data 3-9

How to Determine Correct Hose Assembly Length _____	3
Hose Routing and Installation _____	4
Cleaning, Inspection, Testing and Storage of Hose Assemblies _____	4
Analyzing Failures _____	5
How to Order Thorburn Hose Assemblies _____	7
Flow Capacities of Hose Assemblies at Recommended Flow Velocities _____	8
Hose Pressure Drop _____	9

Hydraulic Hoses 10-13

Low Pressure Hoses _____	10
Medium Pressure Hoses _____	11
High Pressure Hoses _____	12
Extra High Pressure Hoses _____	12
Extra Extra High Pressure Hoses _____	13

Ferrules & Stems 14-35

Thor-Crimp Series I Ferrules & Stems for TC4 & TG4H Hoses _____	14
Series II Ferrules for TC1T, TC2T, TM4K, TG3K, TG2AT-HMP & TM2T Hoses _____	15
Thor-Crimp Series II Stainless Steel Stems & Ferrules _____	16
Thor-Crimp Series II Carbon Steel Stems & Ferrules _____	17-21
British Threading _____	22
Komatsu & JIS Couplings _____	23
DIN (Deutsche Industrial Norme) Couplings _____	24-25
Thor-Crimp Series IV Stainless Steel Spiral (TCS) Stems and Ferrules for TC12 & TR9R Hose _____	26-28

Thor-Crimp Series IV Carbon Steel Ferrules & Stems for TC12 & TR9R Hose _____	29-31
---	-------

Thor-Crimp Series VI Stainless Steel (TCH) Stems for TC13 & TG6K Hose _____	32
---	----

Thor-Crimp Series VI (TCH) Carbon Steel Stems & Ferrules for TC13 & TG6K Hose _____	33-35
---	-------

Pressure Washer Hose Assemblies 38-40

Aqua Therm Series _____	38-39
Elastomeric Waterblast _____	40

Special Purpose Hose Assemblies 41-48

Thermoplastic Hose _____	41-42
Medium Pressure Hose _____	43
Military Low Pressure Hose _____	44-45
Couplings For Special Purpose Hoses _____	46-48

Accessories 49

Protective Nylon Sleeve _____	49
-------------------------------	----

Quick Couplings 50-58

ISO Series NT82 Straight-Through Quick Disconnect Couplings _____	51
ISO Series T61 Interchange Quick Disconnect Couplings _____	52
ISO Series NT72 Interchange Series Quick Disconnect Couplings _____	53
Series T70 High Pressure Quick Disconnect Couplings _____	54-55
Series T71 Flush Face Dry Break Couplings _____	56
Series N75 High Pressure Couplings _____	57
Thorburn's Warranty _____	58

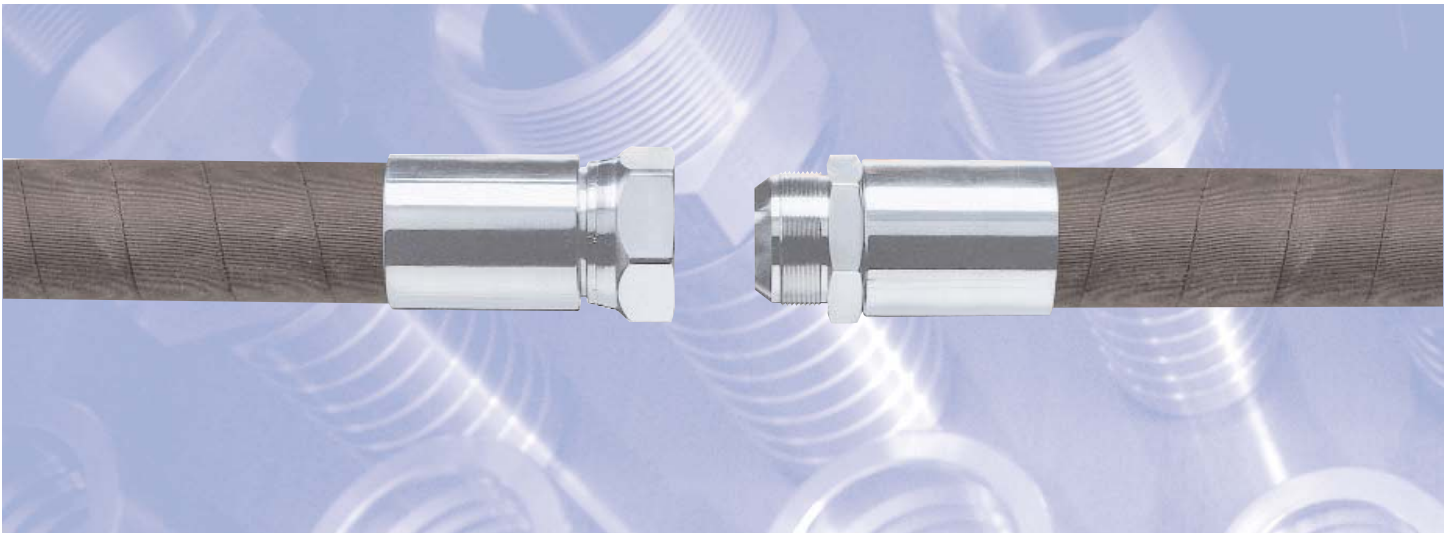

Thorburn's Stainless Steel Braiding Technology

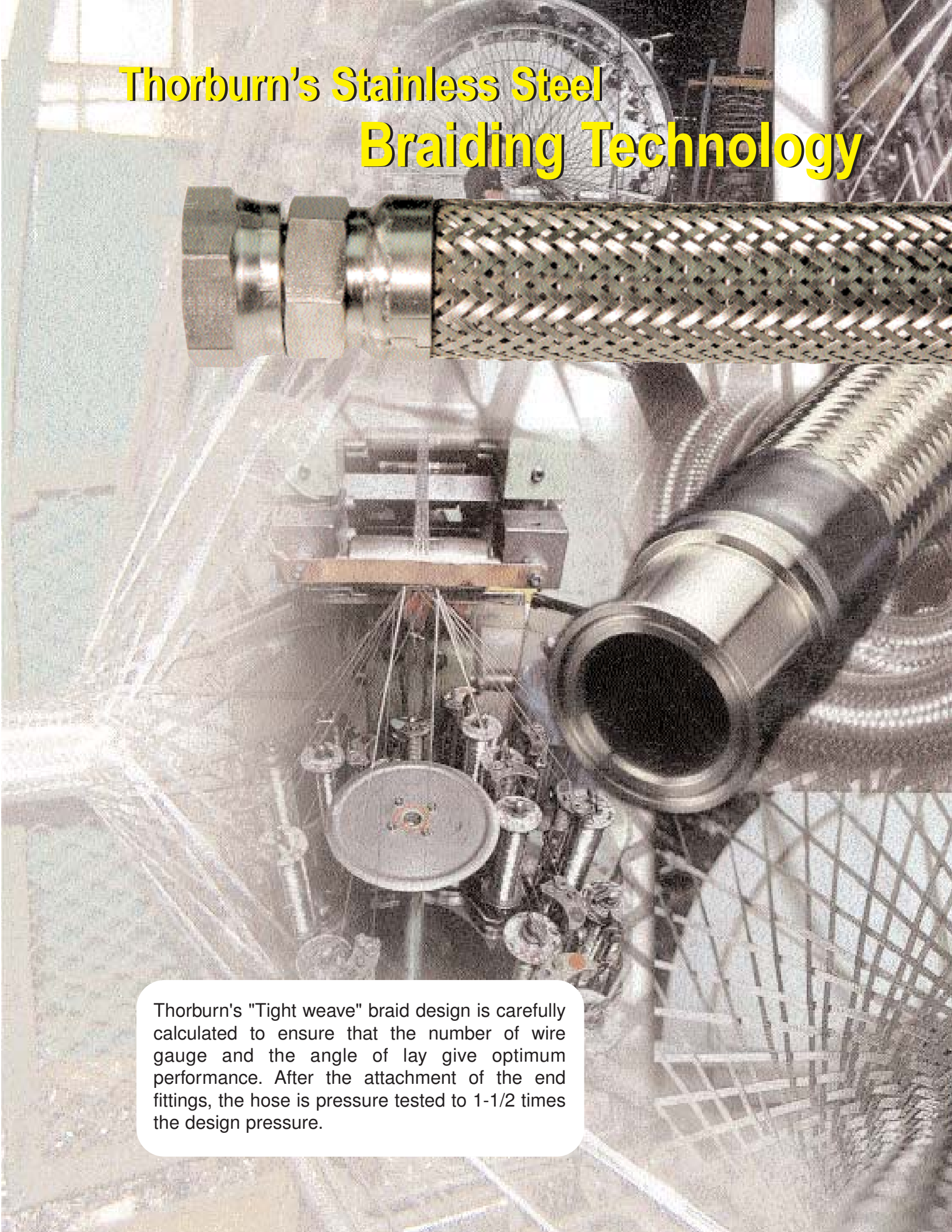

Thorburn's "Tight weave" braid design is carefully calculated to ensure that the number of wire gauge and the angle of lay give optimum performance. After the attachment of the end fittings, the hose is pressure tested to 1-1/2 times the design pressure.

How to Determine Correct Assembly Length



For most assemblies, the correct assembly length may be determined by direct measurement of the equipment or a drawing. Minimum bend radii as shown in the hose specification tables should be observed.

To determine the length of hose needed in making assemblies with permanent or reusable couplings, subtract "Dimension C" for each coupling from the required overall assembly length. "Dimension C" may be found in the coupling specification tables.

Occasionally, an assembly will be required similar to the sketch to the right. The following equation is helpful in determining the correct length:

For 180° Turn Applications:
 $L=2S + 3.14R + T$

- L - The overall length of the hose assembly, in inches.
- S - An allowance for a minimum straight section hydraulic hose at each end of the assembly, measured from the outer end of each coupling, in inches. These two straight sections are necessary to prevent excessive stress concentrations directly back of the couplings. See table at right.
- R - The bending radius of the hose, in inches. See hose specification tables.
- T - The amount of travel, in inches.

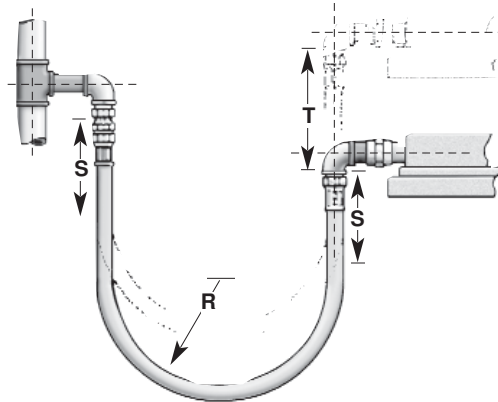

Hose ID (inches)	Minimum S (inches)
3/16	5
1/4	5
5/16	5
3/8	5
13/32	5
1/2	6
5/8	6
3/4	7
7/8	7
1	8
1 1/8	9
1 1/4	9
1 3/8	10
1 1/2	10
1 5/8	11
2	11

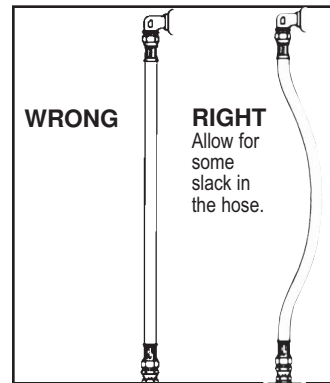
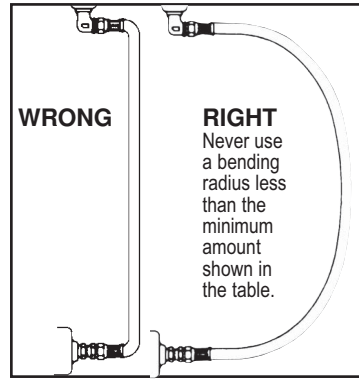
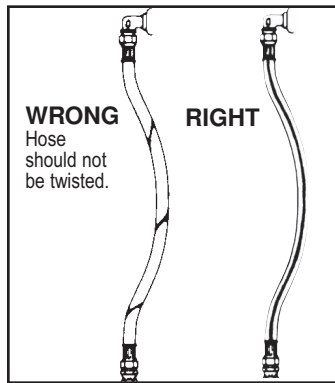

Another point to remember is that hydraulic hose under pressure will elongate up to 2% of its length or contract up to 4% depending on pressure, type and size. Sufficient allowance should be made to permit such changes in length.

Length Tolerances for Hydraulic Hose Assemblies and Specified Hose Lengths

(Reprinted from National Hose Assemblies Manufacturers Association NHAM-STD-2)

Length	Tolerance
For lengths from 0" and up to and including 12"	±1/8"
For lengths above 12" and up to and including 18"	±3/16"
For lengths above 18" and up to and including 36"	±1/4"
For lengths above 36" and up to and including 48"	±3/8"
For lengths above 0" and up to and including 72"	±1/2"
For lengths above 72"	±1°

Length measured to 1/8 of an inch

Angle Couplings

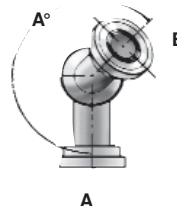

A - To measure angle of offset of a hose assembly, point one end of coupling "A" to a vertical position downward. The angle can then be measured from the centreline of this vertical coupling in a clockwise direction to the centreline of coupling "B" (see illustration)

L - Length from centreline of flanged head to centreline of flanged head for length of assembly.

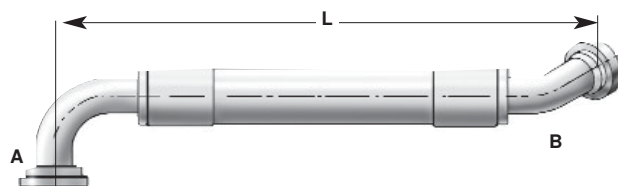

Hose Routing and Installation

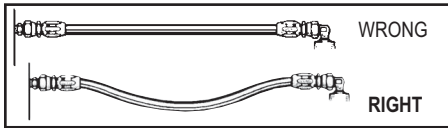

Under pressure, a hose's length may change. Always provide some slack in the hose to allow for shortening or elongation. However, excessive slack in hose lines may cause poor appearance.

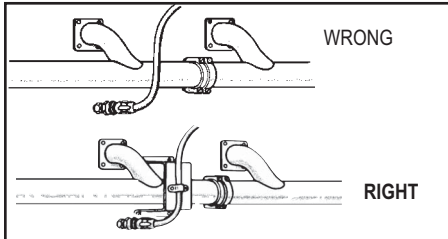

When hose lines pass near an exhaust manifold or other heat source, they should be insulated by a heat resistant boot, firesleeve or a metal baffle. In any application, brackets and clamps keep hoses in place and reduce abrasion. For installations where abrasion to the hose cover cannot be prevented by using clamps or brackets, a steel protective coil or abrasion resistant sleeve should be placed over the hose.

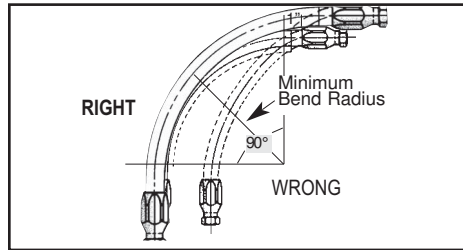

At bends, provide sufficient hose to avoid a bend radius less than the hose's recommended minimum bend radius. Too tight a bend may kink the hose and restrict or snap the fluid flow. In most cases, the proper use of adapters and hose fittings can eliminate tight bends or kinks.

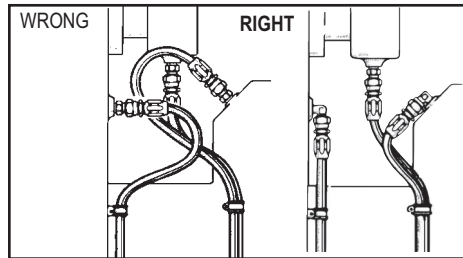

When 90° adapters are used, this assembly becomes neater looking, easier to inspect and maintain, and uses less hose.



If a hose is installed with a twist in it, operating pressures tend to force it to straighten. This can loosen the fitting nut. Twisting can cause reinforcement separation and the hose could burst at the point of strain.

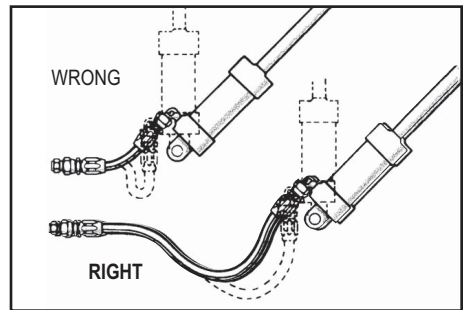

In applications where there is considerable vibration or flexing, allow additional hose length. The metal hose fittings, naturally, are not flexible, and proper installation protects metal parts from undue stress, and avoids kinks in the hose.

Cleaning, Inspection, Testing and Storage of Hose Assemblies

Maintenance

Hose assemblies in operation should be inspected frequently for leakage, kinking, abrasion, corrosion or any other signs of wear or damage. Worn or damaged hose assemblies should be replaced immediately.

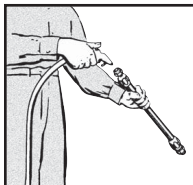

Clean

Clean assembly by blowing out with clean compressed air. Assemblies may be rinsed out with mineral spirits if the tube stock is compatible with oil. Otherwise hot water at 150°F. maximum may be used. Consult Thorburn for special cleaning equipment.



Inspect

Examine hose assembly internally with a borescope or flashlight for cut or bulged tube, obstructions, and cleanliness. Check for proper gap

between nut and socket or hex and socket. Nuts should swivel freely. Check the layline of the hose to be sure that the assembly is not twisted. Cap the ends of the hose with plastic covers to keep clean.

Proof test (hydrostatic)

The hose assembly should be hydrostatically tested at twice the recommended working pressure of the hose.

Test pressure should be held for not more than one minute and not less than 30 seconds. When test pressure is reached, visually inspect hose assembly for: any leaks or signs of weakness; any movement of the hose fitting in relation to the hose. Any of these defects are cause for rejection.

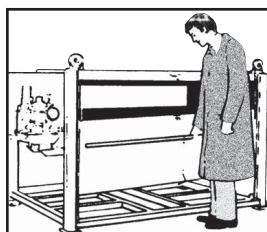

Caution: testing should be conducted in approved test stands with adequate guards to protect the operator.

Proof test (pneumatic)

Hose assemblies intended for gas or air service should be tested with air or nitrogen at 100 psi with the assembly immersed in water. Random bubbles may appear over the hose and fitting area when assembly is first pressurized. This should not be construed as a defect. However, if the bubbles persist in forming at a steady rate at any particular point on the hose, the assembly should be rejected.

Caution: testing should be conducted in approved test stands with adequate guards to protect the operator.

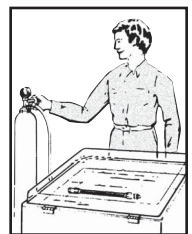

Storage and handling

Hose should be stored in a dark, dry atmosphere away from electrical equipment, and the temperature should not exceed 90°F. Storage in the original shipping container is preferred.

Analyzing Failures

Hose failures normally aren't a problem—the hose is replaced and the equipment goes back in operation. However, when the same problems keep occurring with the same equipment, one must determine their causes and correct them.

Improper Application

Begin with the most obvious and common cause of hose failures, improper application, and compare the hose specifications with the requirements of the application. Pay attention especially to the following:

1. Maximum operating pressure of the hose.
2. Recommended temperature range of the hose.
3. Whether the hose is rated for vacuum service.
4. Fluid compatibility of the hose.

Check these against the requirements of the application. If they don't match up, another hose must be selected. A Thorburn representative can help you select the proper hose.

Improper Assembly and Installation

The second major cause of premature hose failures is improper assembly and installation procedures. This can involve any factor from using the wrong hose fitting to poor routing of the hose. Your Thorburn representative can help you solve this problem.

External Damage

External damage ranges from abrasion and corrosion to a hose crushed by a forklift truck. Once the cause is identified, most of these problems are easily solved. The hose can be re-routed or clamped or a fire sleeve or abrasion guard can be used. With corrosion, the solution may simply be to switch to a hose with a more corrosion resistant cover or re-routing the hose away from the corrosive element.

Faulty Equipment

A malfunction in equipment is a factor to be considered since prompt corrective action can avoid serious and costly equipment breakdown.

Faulty Hose

Sometimes a failure is caused by the hose itself. The likeliest cause of a faulty rubber hose is old age. Check the lay line on the hose to determine the date of manufacture. The hose may have exceeded its recommended shelf life. If, after exhausting other possibilities, you suspect the problem is in the manufacture of the hose, contact Thorburn. Given effective quality control methods, the odds of a faulty hose being released for sale are tiny.

Analyzing Failures

A physical examination of the failed hose can often offer a clue to the cause of failure. Following are 20 symptoms to look for, along with the conditions causing them:

1. **Symptom:** The hose tube is very hard and has cracked.

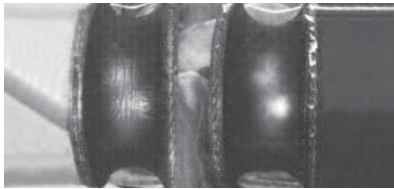

Cause: Heat has a tendency to leach the plasticizers out of the tube. This is a material that gives the hose its flexibility or plasticity. Aerated oil causes oxidation to occur in the tube. This reaction of oxygen and heat will greatly accelerate the hardening of the hose tube. Cavitation occurring inside the tube would have the same effect.

2. **Symptom:** The hose is cracked both externally and internally but the elastomeric materials are soft and flexible at room temperature.



Cause: Probably the hose was flexed under intense cold ambient conditions. Most standard hoses are rated to -40°F (-40°C). Some Thorburn hoses are rated at -55°F (-49°C). Military specified hoses are commonly rated to -65°F (-54°C). Teflon hose is rated to -100°F (-73°C). Some Polyon thermoplastic hoses are rated -65°F (-54°C).

3. **Symptom:** The hose has burst. Examination of the wire reinforcement after stripping back the cover reveals random broken wires the entire length of the hose.



Cause: This points to a high frequency pressure impulse condition. SAE impulse test requirements for a double wire braid reinforcement are 200,000 cycles at 133% of the recommended working pressure. The SAE impulse test requirements for a four spiral wrapped braid reinforcement (100R9) are 300,000 cycles at 133% of the recommended working pressure and at 200°F (93°C). If the extrapolated impulses in a system amount to over a million in a relatively short time a spiral reinforced hose would be the better choice.

4. **Symptom:** The hose has burst, but there is no indication of multiple broken wires the entire length of the hose. The hose may have burst in more than one place.

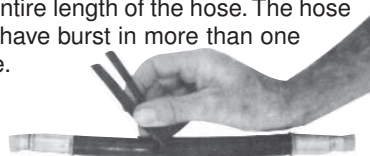

Cause: The pressure has exceeded minimum strength of the hose. Either a stronger hose is needed or the hydraulic circuit has a malfunction which is causing unusually high pressure conditions.

5. **Symptom:** The hose has burst. An examination reveals that the wire braid is rusted and the cover has been cut, abraded or

deteriorated badly.

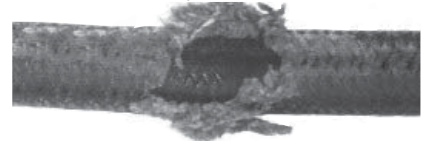

Cause: The primary function of the cover is to protect the reinforcement. Elements that may destroy or remove the hose covers are:

1. abrasion
2. cutting
3. battery acid
4. steam cleaners
5. chemical cleaning solutions
6. muriatic acid (for cement clean-up)
7. salt water
8. heat
9. extreme cold

Once the cover protection is gone, the wire reinforcement is susceptible to attack from moisture or other corrosive matter.

6. **Symptom:** The hose has burst on the outside bend and seems elliptical in the bent section. In the case of the pump supply line, the pump is noisy and very hot. The exhaust line on the pump is hard and brittle.

Cause: In both cases, the likeliest cause is a violation of the minimum bend radius. Check the minimum bend radius and make sure that it is within specifications. In the case of pump supply line partial collapse of the hose is causing the pump to cavitate creating both noise and heat. This is a most serious situation and will result in catastrophic pump failure if not corrected.

7. **Symptom:** The hose appears flattened out in two areas and kinked. It has burst in this area and also appears twisted.



Cause: Torquing of a hydraulic control hose tears loose the reinforcement layers and allows the hose to burst through enlarged gaps between the braided plaits of wire strands. Use swivel fittings or joints to avoid a twisting force on a hydraulic hose.

8. **Symptom:** The hose tube is broken loose from the reinforcement and piled up at the end of the hose. It may protrude from the end of the hose fitting.

Cause: Likely cause: high vacuum or wrong hose for the vacuum service. No vacuum is recommended for double wire braid, 4 and 6 spiral wire hose unless an internal coil support is used. This type of failure may happen even to a hose rated for vacuum service, if it is kinked, flattened out or bent too sharply.

9. **Symptom:** The hose has burst about six to eight inches away from the end fitting. The wire braid is rusted. There are no cuts or abrasions of the outer cover.

Cause: Improper assembly of the hose end fitting allows moisture to enter around the edge of the fitting socket. The moisture will wick through the reinforcement. The heat generated by the system will drive it out around the fitting area, but six inches away it will be trapped between inner liner and outer cover, causing corrosion of the wire reinforcement.

10. **Symptom:** There are blisters on the cover of the hose. If one pricks the blisters, oil will be found in them.

Cause: A tiny pinhole in the hose tube is allowing high pressure oil to seep between it and the cover. Eventually, it will form a blister where the cover adhesion is weakest. For a screw-together reusable fitting, insufficient lubrication of the hose and fitting can cause this condition because the dry tube will adhere to the rotating nipple and tear enough to allow seepage. Faulty hose can also cause this condition.

11. **Symptom:** Blistering of the hose cover where a gaseous fluid is being used.



Cause: High pressure gas effuses through the hose tube, gathering under the cover and soon forming a blister where the adhesion is weakest. Specially constructed hoses are available for high pressure gaseous applications. Your Thorburn representative can advise you on the proper hose to use in these cases.

12. **Symptom:** Fitting blew off end of hose.

Cause: Wrong fitting on the hose. Recheck Thorburn's specifications and part numbers.

For a crimped fitting, the wrong machine setting can result in over- or undercrimping. The socket of a screw together fitting for multiple wire braided hose may be worn beyond its tolerance. The swaging dies in a swaged hose assembly may be worn beyond Thorburn's tolerances.

The fitting may have been applied improperly to the hose. Check Thorburn's instructions. The hose may have been installed without leaving enough slack to compensate for the possible 4% shortening that may happen when a hose is pressurized, imposing great force on the fitting. The hose itself may be out of tolerance.

13. **Symptom:** The tube of the hose is badly deteriorated with evidence of extreme swelling. In some cases, the hose tube may be "washed out".



Cause: This indicates that the hose tube is not compatible with the agent being carried. Even though the agent is normally compatible, the addition of heat can be the catalyst that can

cause inner liner deterioration. Consult Thorburn for a compatibility list. Make sure neither the internal nor the external operating temperatures exceed recommendations.

14. **Symptom:** The hose has burst. The hose cover is badly deteriorated and the surface of the rubber is crazed.

Cause: This could be simply old age. The crazed appearance is the effect of weathering and ozone over a period of time. Try to determine the age of the hose. Thorburn prints or embosses the date on the outside of the hose.

15. **Symptom:** The hose leaks at the fitting because of a crack in the metal tube adjacent to the braze on a split flange head.

Cause: Because the crack is adjacent to the braze, this is a stress failure brought on by a hose that is trying to shorten under pressure, but doesn't have sufficient slack to do so. This problem can be cured by lengthening the hose assembly or altering the routing to relieve the forces on the fitting.

16. **Symptom:** A spiral reinforced hose has burst and literally split open with the wire exploded out and badly entangled.



Cause:

The hose is too short to accommodate the change in length occurring while it is pressurized.

17. **Symptom:** The hose hasn't burst, but is leaking profusely. A bisection of the hose reveals that the tube has been gouged through to the wire braid for a distance of about two inches.

Cause: Indicates erosion of the hose tube. A high velocity needle-like fluid stream being emitted from an orifice and impinging at a single point on the hose tube will hydraulically remove a section of it. Be sure the hose is not bent close to an orificed port.

18. **Symptom:** The hose is badly flattened out in the burst area. The tube is very hard downstream of the burst but appears normal upstream of the burst.



Cause: The hose has been kinked either by bending it too sharply or by squashing it so as to create a major restriction. As the velocity of the fluid increases through the restriction, the pressure decreases to the vaporization point of the fluid being conveyed. Often called cavitation, it causes heat and rapid oxidation to occur, hardening the hose tube downstream of the restriction.

19. **Symptom:** The hose fitting has been pulled out of the hose. The hose has been considerably stretched out in length. This may not be a high pressure application.

Cause: Insufficient support of the hose. Very long lengths of hose must be supported, especially if vertical. Otherwise, the weight of the hose along with the weight of the fluid in it will be imposed on the hose fitting. This force can be transmitted to a wire rope or chain by clamping the hose to it much like the utilities support bundles of wire from pole to pole. Leave sufficient slack in the hose between clamps to compensate for possible 4% shortening that can occur when the hose is pressurized.

20. **Symptom:** The hose has not burst, but it leaks profusely. A bisection of the hose reveals an inward burst.

Cause: Often known as hose tube blow-down, this type of failure is usually associated with very low viscosity fluids such as air, nitrogen, freon, and other gases. Under high pressure conditions, the gases effuse into the pores of the hose tube charging them up like miniature accumulators. If the pressure is suddenly reduced to zero, the entrapped gases literally explode out of the tube, often tearing holes in it. In some hose constructions, a second hose tube made from a plastic such as nylon, is inserted into the hose.

A small leak allows the gaseous fluid to seep between the two inner liners and when the pressure is reduced to zero, the innermost liner will collapse because of the trapped pressure around its outer diameter.

HOW TO ORDER THORBURN HOSE ASSEMBLIES

The example shown here:
TC4 3/4" Hose with Series I "O" Ring Flange Straight 3/4" at first end and Thorcrimp NPTF Solid Male 3/4" at second end.



Size/Hose code	Thor-Crimp Series	1st End Size/Coupling	1st End Material	2nd End Size/Coupling	2nd End Material	Overall Length in inches	Option/Cover
12TR4	I	12FL	S6	12MP	S6	240"	

Hose Type	
TR1T	Medium pressure
TR17	High pressure
TR2AT	High pressure
TR16	High pressure
TR12	Extra high pressure
TR13	Extra extra high pressure
TR15	Extra extra high pressure
TR7NC	Special Purpose
TR8NC	Special Purpose

Series
II = 2
IV = 4
VI = 6

Coupling Type	
MP	NPTF Solid Male
MPX	NPTF Swivel Male
FP	NPTF Solid Female
FPX	NPTF Swivel Female
BM	Bulkhead Male NPTF
BF	Bulkhead Female NPTF
MJ	JIC Solid Male
MJX	JIC Swivel Male
FJX	JIC Swivel Female
FJX45	JIC Swivel Female 45° Bent Tube
FJX90	JIC Swivel Female 90° Bent Tube
FJX90S	Short JIC Swivel Female 90° Bent Tube
FJX90L	Long JIC Swivel Female 90° Bent Tube
MB	"O" Ring Boss Solid Male
MBX	"O" Ring Boss Swivel Male
MBX45	"O" Ring Boss Swivel Male 45°
MBX90	"O" Ring Boss Swivel Male 90°
MBX90L	"O" Ring Boss Swivel Male 90° Long Radius
MFA	SAE Male Flareless
MFF	Male Flat Face "O" Ring
FFX	Female Flat Face "O" Seal Swivel Straight
FFX45	Female Flat Face "O" Seal Swivel 45° Bent Tube
FFX90	Female Flat Face "O" Seal Swivel 90° Bent Tube
FL	"O" Ring Flange Straight, code 61-SAE J518
FL45	"O" Ring Flange 45°, code 61-SAE J518
FL90	"O" Ring Flange 90°, code 61-SAE J518
FLH	"O" Ring Flange Straight, code 62-SAE J518
FLH22	"O" Ring Flange 22°, code 62-SAE J518
FLH30	"O" Ring Flange 30°, code 62-SAE J518
FLH45	"O" Ring Flange 45°, code 62-SAE J518
FLH60	"O" Ring Flange 60°, code 62-SAE J518
FLH90	"O" Ring Flange 90°, code 62-SAE J518
MBSPT	BSPP Solid Male Tapered
MBSPP	BSPP Solid Male Parallel
FBSPP	BSPP Swivel Female
FBSPPX45	BSPP Swivel Female 45° Bent Tube
FBSPPX90	BSPP Swivel Female 90° Bent Tube
MDL	DIN Male Light Series
MDH	DIN Male Heavy Series
FDLX	DIN Female Swivel Straight Light Universal 24°/60° Inverted Cone
FDLX45	DIN Female Swivel Light Series 45° Bent Tube
FDLX90	DIN Female Swivel Light Series 90° Bent Tube
FDSX	DIN Female Swivel Straight Heavy Series 24° Inverted Cone with "O" Ring
FDHX45	DIN Female Swivel Straight Heavy Series 45° Bent Tube
FDHX90	DIN Female Swivel Straight Heavy Series 90° Bent Tube
FKX	Female Swivel Komatsu
FKX45	Female Swivel Komatsu 45° Bent Tube
FKX90	Female Swivel Komatsu 90° Bent Tube
JISX	JIS Female Swivel
JISX45	JIS Female Swivel 45°
JISX90	JIS Female Swivel 90°

Materials	
Material Codes:	
C	Carbon Steel
S6	Stainless Steel 316
S4	Stainless Steel 304
B	Brass

Accessories & Options	
C	Coupler
N	Nipple
DP	Dust Plug
DC	Dust Cap

Quick Couplings	
T61	ISO Series A Interchange
T72	ISO Series B Interchange
T71	Series T71 Flush Face/Dry Break
NT82	Series NT82 High Pressure

Nominal Fitting & Hose Size	
Hose size in 1/16"	
Examples:	
01	= 1/16"
02	= 1/8"
04	= 1/4"
06	= 3/8"
08	= 1/2"
12	= 3/4"
32	= 2"
etc.	

Flow Capacities of Hose Assemblies at Recommended Flow Velocities

The nomographic chart will help you select the correct hose size for a given hydraulic system. The velocity of the hydraulic fluid should not exceed the range shown in the right-hand column. When oil velocities are higher than recommended in this chart, the results are: turbulent flow with loss of pressure and excessive heating. Higher velocities may be used if the flow of hydraulic fluid is intermittent or only for short periods of time.

The velocity of hydraulic fluid in suction lines should always fall within the range recommended, to insure efficient operation of the pump.

The following example will familiarize you with the use of this chart:

What size hose assembly is recommended to carry ten gallons of oil per minute, and what will be the velocity of the oil through the hose assembly? The hose assembly is to be used in a pressure line and flow is to be continuous.

Locate the flow, 10 gallons per minute (left-hand column) and a velocity, **10 ft. per second** (right-hand column), since it is near the center of the recommended range. Lay a straight edge across these two points. The straight edge crosses the center column nearest to the **5/8"** hose assembly. Keeping the straight edge on **10 gallons per minute** in the left-hand column, cross the center column at the **3/4"** assembly, the **5/8"** assembly and **1/2"** assembly. Rereading the right-hand column, the straight edge crosses it at **7.5**, **10.3** and **16** ft. per second respectively. Since **7.5** and **10.3** are within the recommended velocity range for pressure lines, either a **3/4"** or **5/8"** hose assembly may be used.

Problems concerning suction hoses are worked in a similar manner, except that the recommended velocity range for intake line (right-hand column) and the values for suction hose assemblies (center column) are used.

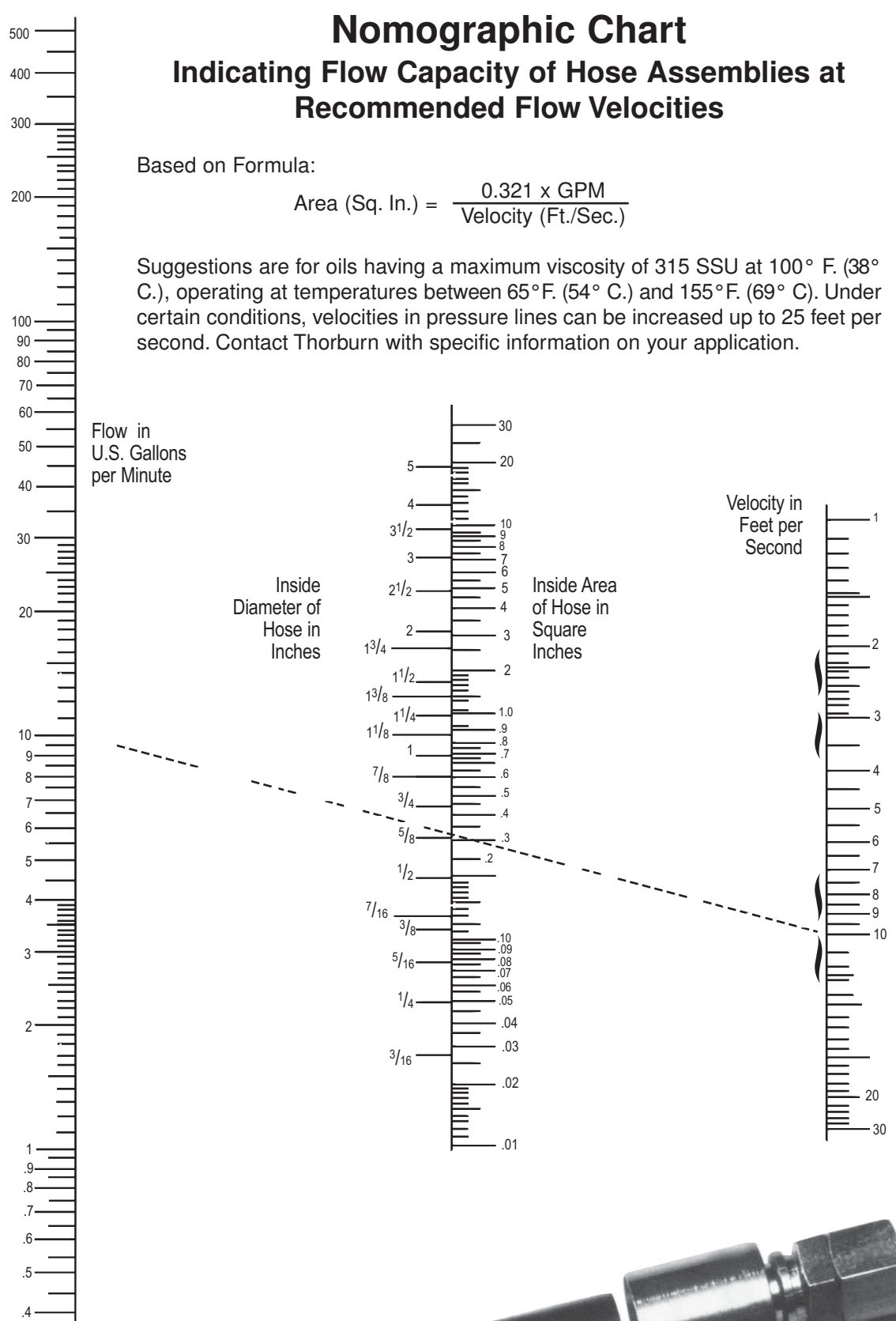

Hose Pressure Drop

Pressure drop in psi (pounds per square inch) / gpm (gallons per minute) for 10 feet of hose (smooth bore) without fittings.

Fluid specifications: Specific gravity=.85; Viscosity= ν =20 centistokes (C.S.), (20 C.S. = 97 S.S.U.).

Hose Dash Size →	-03	-04	-05	-06	-08	-10	-12	-16	-20	-24	-32	-40	-48
Hose ID (inches)	.19	.25	.31	.38	.50	.63	.75	1.00	1.25	1.50	2.00	2.38	3.00
.25	10	3.1											
.50	19	6	2.7										
1	40	12	5.5	2.4									
2	95	24	10	4.8									
3	185	46	17	7	2.2								
4		78	29	12	3	1.2							
5		120	44	18	4.5	1.6	.72						
8			95	39	10	3.6	1.4						
10				59	15	5.7	2	.55					
12				80	20	7.2	2.6	.75					
15					30	10	4.2	1.2	.38				
18					40	15	6.3	1.5	.55				
20					49	19	8	2	.65	.27			
25					72	26	11	3	1	.40			
30						34	14	3.6	1.3	.52	.14		
35						47	19	5	1.7	.70	.18		
40							25	6.5	2.2	.90	.24		
50							36	9	3.3	1.3	.35	.15	
60							50	12	4.4	1.8	.45	.20	
70								17	6	2.4	.65	.30	
80								21	7.1	3	7.6	.34	.11
90								27	9	3.8	1	.45	.13
100								33	12	4.7	1.3	.55	.18
150								60	22	8.5	2.2	1	.33
200									36	15	3.9	1.7	.55
250									54	22	5.3	2.5	.75
300										29	7.5	4	1.1
400										51	14	6.5	2.2
500											20	10	3
800												18	5
1000													10

U.S. gallons per minute

Pressure drop values listed are typical of many petroleum based hydraulic oils at approximately 100°F. (38°C).

Differences in fluids, fluid temperature and viscosity can increase or decrease actual pressure drop compared to the values listed.

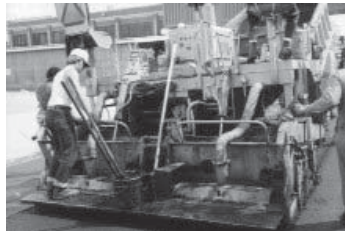

Medium Pressure

1-Wire Braid Hose SAE 100R1 Type AT

One wire braid hose. "No-Skive" type hydraulic hose. Meets or exceeds requirements of SAE 100R2, Type AT. Excellent high and low temperature range. Hose also meets Flame Resistance Acceptance Designation U.S. MSHA 2G. No skiving required.

Recommended for: Medium pressure hydraulic oil lines.

Temperature Range: -40°C to +100°C (-40°F to +212°F). Higher temperature compounds available.

Couplings: Thor-Crimp Couplings Series II pages 15-24.

Tube: Black. Oil resistant synthetic rubber.

Reinforcement: One braid of high tensile steel wire.

Cover: Black. Oil and abrasion resistant, thin synthetic rubber.



TR1
No skive

Thorburn Part #	Hose ID in.	Hose OD in.	Operating Pressure	Min. Burst	Min. Bend in.	Weight 100ft
3TR1	3/16	.46	3000	12000	3.5	13
4TR1	1/4	.52	2750	11000	4	15
5TR1	5/16	.57	2500	10000	4.5	16
6TR1	3/8	.68	2250	9000	5	23
8TR1	1/2	.81	2000	8000	7	28
10TR1	5/8	.92	1500	6000	8	35
12TR1	3/4	1.09	1250	5000	9.5	41
16TR1	1	1.41	1000	4000	12	59
20TR1	1 1/4	1.72	625	2500	16	88
24TR1	1 1/2	1.99	500	2000	20	103
32TR1	2	2.52	375	1500	25	138

1-Wire Braid Hose 3000 psi SAE 100R17 Half the bend radius of SAE 100R1

Recommended for: Medium pressure hydraulic oil lines. Exceeds SAE performance requirements because TM3K hose has smaller interior dimensions and **significantly tighter bend radius... up to half SAE rating.**

Temperature Range: -40°C to +100°C (-40°F to +212°F).

Couplings: Thor-Crimp Couplings Series II pages 15-24.

Tube: Black, oil resistant synthetic rubber.

Reinforcement: Braided high tensile steel wire.

Cover: Black. Oil, abrasion and weather resistant, synthetic rubber.



TR17
No skive

Thorburn Part #	Hose ID in.	Hose OD in.	Operating Pressure	Min. Burst	Min. Bend in.	Weight 100 ft
4TR17	1/4	.47	3000	12000	2.0	11
6TR17	3/8	.62	3000	12000	2.5	18
8TR17	1/2	.78	3000	12000	3.5	27
10TR17	5/8	.98	3000	12000	4.0	49
12TR17	3/4	1.14	3000	12000	4.75	60
16TR17	1	1.48	3000	12000	6.0	95
20TR17	1 1/4	1.85	3000	12000	8.25	179
24TR17	1 1/2	2.11	3000	12000	20	26.8
32TR17	2	2.63	3000	12000	25	33.6

2-Wire Braid Hose SAE 100R2 Type AT

"No-Skive" type hydraulic hose. Meets or exceeds requirements of SAE 100R2, Type AT. Used with Thorcrimp where "No-Skive" hose is required. Excellent high and low temperature range. Hose also meets Flame Resistance Acceptance Designation U.S. MSHA 2G.

Recommended for: Medium pressure hydraulic oil lines, fuel oil, or water. Used on all types of hydraulic systems for mobile and stationary equipment.

Temperature Range: -40°C to +100°C (-40°F to +212°F). Higher temperature compounds available.

Couplings: Thor-Crimp Couplings Series II pages 15-24.

Tube: Black. Oil resistant synthetic rubber.

Reinforcement: Two braids of high tensile steel wire.

Cover: Black. Oil and abrasion resistant, thin synthetic rubber.



TR2
No skive

Thorburn Part #	Hose ID in.	Hose OD in.	Operating Pressure	Min. Burst	Min. Bend in.	Weight 100 ft
4TR2	1/4	.59	5000	20000	4	25
6TR2	3/8	.74	4000	16000	5	36
8TR2	1/2	.88	3500	14000	7	44
10TR2	5/8	.97	2750	11000	8	49
12TR2	3/4	1.13	2250	9000	9.5	60
16TR2	1	1.46	2000	8000	12	86
20TR2	1 1/4	1.87	1625	6500	16.5	145
24TR2	1 1/2	2.15	1250	5000	20	164
32TR2	2	2.65	1125	4500	25	205

High Pressure

2-Wire Braid Hose SAE 100R16 Half the bend radius of SAE 100R2

"No-Skive" type hydraulic hose. of SAE 100R2, Type AT. Used with Thorburn Thorcrimp System where "No-Skive" hose is required. Excellent high and low temperature range.

Recommended for: High pressure hydraulic oil lines. Meets or exceeds SAE requirements, with smaller exterior dimensions and significantly tighter bend radius.

Temperature Range: -40°C to +100°C (-40°F to +212°F).

Couplings: Thor-Crimp Couplings Series II pages 15-24.

Tube: Black. Oil resistant synthetic rubber.

Reinforcement: Two braids of high tensile steel wire.

Cover: Black. Oil and abrasion resistant.

TR16 No skive

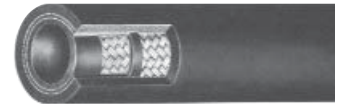

Thorburn Part #	Hose ID in.	Hose OD in.	Operating Pressure	Min. Burst	Min. Bend in.	Weight 100 ft
4TR16	1/4	.54	5000	20000	2.00	21
6TR16	3/8	.69	4000	16000	2.50	30
8TR16	1/2	.81	3500	14000	3.5	35
10TR16	5/8	.95	2750	11000	4.00	42
12TR16	3/4	1.10	2250	9000	4.75	52
16TR16	1	1.38	2000	8000	6.00	70

Extra High Pressure

4-Spiral Wire Hose SAE 100R12

Recommended for: Extra high pressure hydraulic applications. Excellent impulse life; surpassed 1,000,000 impulse cycles when tested with PCS series couplings at 250°F (at SAE 100R12 conditions) and at 133% of rated working pressure.

Temperature Range: -40°C to +121°C (-40°F to +250°F).

Couplings: Thor-Crimp Couplings Series IV pages 25-26.

Tube: Black. Oil resistant synthetic rubber.

Reinforcement: Four alternating layers of spiraled high tensile steel wire over a fabric layer.

Cover: Black. Oil resistant synthetic rubber.

TR12



Thorburn Part #	Hose ID in.	Hose OD in.	Operating Pressure	Min. Burst	Min. Bend in.	Weight 100 ft
6TR12	3/8	.80	4000	16000	5	48
8TR12	1/2	.94	4000	16000	7	58
*12TR12	3/4	1.21	4000	16000	9.5	92
*16TR12	1	1.50	4000	16000	6	127
*20TR12	1 1/4	1.85	3000	12000	16.5	179
24TR12	1 1/2	2.13	2500	10000	20	191
32TR12	2	2.63	2500	10000	25	277

Spiral Wire Hose SAE100R13 5000 psi

Hose meets Flame Resistance Acceptance Designation U.S. MSHA 2G.

Recommended for: Extremely high pressure hydraulic applications. Meets all requirements of the SAE 100R13 specifications.

Temperature Range: -40°C to +121°C (-40°F to +250°F).

Couplings: Thor-Crimp Couplings Series VI "TCH" pages 30-33.

Tube: Black. Oil resistant synthetic rubber.

Reinforcement: Four alternating layers of spiraled high tensile steel wire over a fabric layer on -12 and -16 sizes; six alternating layers of spiraled high tensile steel wire over a fabric layer on -20, -24 and -32 sizes.

Cover: Black. Oil resistant synthetic rubber.

TR13 Skiving required

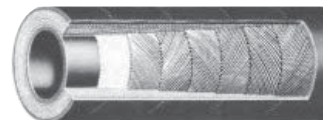

Thorburn Part #	Hose ID in.	Hose OD in.	Operating Pressure	Min. Burst	Min. Bend in.	Weight 100 ft
10TR13	5/8	1.11	5000	20000	8	108
12TR13	3/4	1.26	5000	20000	9.5	108
16TR13	1	1.53	5000	20000	12	148
20TR13	1 1/4	1.97	5000	20000	16.5	250
24TR13	1 1/2	2.26	5000	20000	20	319
32TR13	2	2.81	5000	20000	25	490

Thermoplastic Hose Assemblies

TR7NC Thermoplastic Non-Conductive Hydraulic Hose

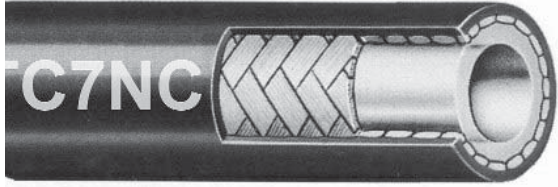

SAE 100R7

CONSTRUCTION

Tube: 100% seamless nylon that easily handles a broad range of hydraulic fluids, including phosphate esters and water glycol. Non-perforated for applications requiring electrical non-conductivity. Meets SAE 100R7 electrical conductivity test.

Reinforcement: Single polyester braid

Cover: Orange urethane that resists hydraulic fluids, high temperatures, aging and weathering.

Couplings: Factory assembled swage type coupling in carbon steel or stainless steel.

Part Number	Hose ID Inches	Hose OD Inches	Design Pressure PSI	Min Burst Pressure PSI	Min Bend Radius Inches	Weight LBS/100FT
2TRNC7	1/8	0.32	2500	10,000	0.5	?
3TRNC7	3/16	0.44	3000	12,000	0.8	?
4TRNC7	1/4	0.51	2750	11,000	1.3	?
5TRNC7	5/16	0.58	2500	10,000	1.8	?
6TRNC7	3/8	0.66	2250	9,000	2.0	?
8TRNC7	1/2	0.82	2000	8,000	3.0	?
12TRNC7	3/4	1.07	1250	5,000	5.0	?
16TRNC7	1	1.33	1000	4,000	8.0	?

TR8NC Thermoplastic Non-Conductive Hydraulic Hose



SAE 100R8

CONSTRUCTION

Tube: 100% seamless nylon that easily handles a broad range of hydraulic fluids, including phosphate esters and water glycol. Non-perforated for applications requiring electrical non-conductivity. Meets SAE 100R8 electrical conductivity test.

Reinforcement: Single aramid fiber braid

Cover: Orange urethane that resists hydraulic fluids, high temperatures, aging and weathering.

Couplings: Factory assembled swage type coupling in carbon steel or stainless steel.

Part Number	Hose ID Inches	Hose OD Inches	Design Pressure PSI	Min Burst Pressure PSI	Min Bend Radius Inches	Weight LBS/100FT
4TRNC8	1/4	0.52	5000	20,000	2.00	?
6TRNC8	3/8	0.66	4000	16,000	2.50	?
8TRNC8	1/2	0.81	3500	14,000	4.00	?

Ferrules for TR1, TR17, TR2, TR16

Series II Ferrule Non-skive

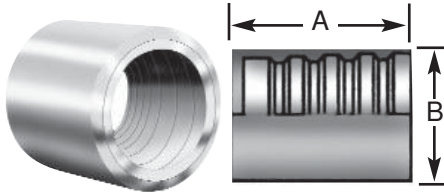

Applicable for hoses TR1, TR2

Thorburn Part #		Hose ID in.	Length A	Length B
Steel	Stainless steel			
3TC2F	391F-03S6	3/16	1.20	.83
4TC2F	391F-04S6	1/4	1.28	.87
5TC2F	391F-05S6	5/16	1.20	.97
6TC2F	391F-06S6	3/8	1.20	1.06
8TC2F	391F-08S6	1/2	1.47	1.15
10TC2F	391F-10S6	5/8	1.47	1.32
12TC2F	391F-2S6	3/4	1.69	1.53
16TC2F	391F-16S6	1	1.69	1.94
20TC2F	391F-20S6	1 1/4	2.41	2.38
24TC2F	391F-24S6	1 1/2	2.69	2.69
32TC2F	391F-32S6	2	3.56	3.25

Aluminium and stainless steel ferrules available on request. Add suffix "-S6" for stainless steel and suffix "-A" for aluminium.

Series II NC Ferrule Non-skive

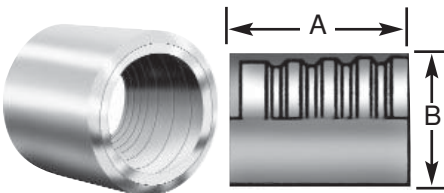

Applicable for hoses TR7NC, TR8NC

Thorburn Part #	Hose ID in.	Length A	Length B
4TNCF	1/4	1.06	.51
5TNCF	5/16	1.14	.67
6TNCF	3/8	1.18	.75
8TNCF	1/2	1.22	.83
10TNCF	5/8	1.34	1.0
12TNCF	3/4	1.69	1.3

The Thor-Crimp Advantage

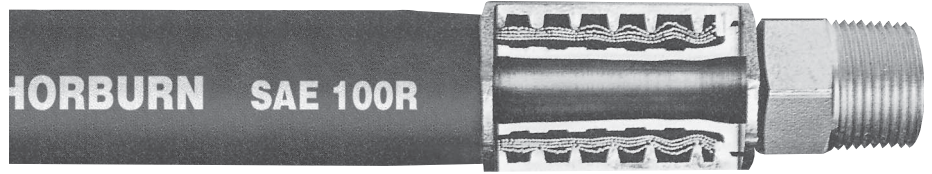

Features:

- Ferrule serrations bite through the cover making contact with wire reinforcement
- Machine-fit locking collar between ferrule and stem
- Low profile finished crimp

Benefits:

- Safety; better holding power and reliability
- Smaller finished crimp; streamlined assemblies; easier to plumb
- Excellent performance

The Thor-Crimp System

A hydraulic hose coupling usually consists of two primary components:

1. A ferrule placed over the end of the hose.
2. A stem inserted into the end of the hose.



No Weld Flanged Elbows

One Piece Flanged Coupling.

- Eliminates Stress Risers
- Safer and more reliable
- Eliminates cracks during vibration

No Welded Joints

Superior Elbow Threaded Couplings

True One Piece Female Swivel Coupling.

No Welded Joints

Thor-Crimp Stainless Steel Stems & Ferrules

NPTF Solid Male

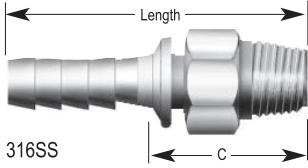

Material: 316SS

Thorburn Part #	Hose ID (in)	Thread Size	Hex Size (in)	Bore Size (in)	Coupling Length (in)	"C" Cut-off (in)
390MP-4-4S6	1/4	1/4-18	.56	.156	2.23	1.14
390MP-6-6S6	3/8	3/8-18	.69	.295	2.22	1.21
390MP-8-8S6	1/2	1/2-14	.88	.406	2.89	1.45
390MP-12-12S6	3/4	3/4-14	1.13	.625	3.22	1.51
390MP-16-16S6	1	1-11 1/2	1.38	.844	3.69	1.98
390MP-20-20S6	1 1/4	1 1/4-11 1/2	1.75	1.062	4.39	2.09
390MP-24-24S6	1 1/2	1 1/2-11 1/2	2.00	1.312	4.82	2.18
390MP-32-32S6	2	2-11 1/2	2.50	1.656	5.86	2.33

Female Flat-Face "O" Seal Swivel Straight

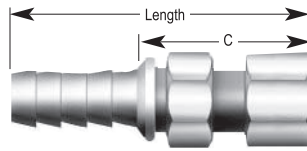

Material: 316SS

Thorburn Part #	Hose ID (in)	Thread Size	Hex A Size (in)	Hex B Size (in)	Bore Size (in)	Coupling Length (in)	"C" Cut-off (in)
390-FFX-4-4S6	1/4	9/16-18	11/16	1/2	.156	2.32	1.23
390-FFX-6-6S6	3/8	11/16-16	13/16	5/8	.265	2.47	1.46
390-FFX-8-8S6	1/2	13/16-16	15/16	13/16	.406	3.10	1.66
390-FFX-10-10S6	5/8	1-14	1 1/8	15/16	.500	3.25	1.81
390-FFX-12-12S6	3/4	1 1/16-12	1 3/8	1 1/16	.625	3.56	1.85
390-FFX-16-16S6	1	1 7/16-12	1 5/8	1 3/8	.844	4.01	2.30
390-FFX-20-20S6	1 1/4	1 11/16-12	1 7/8	1 3/4	1.062	4.51	2.21

JIC Swivel Female

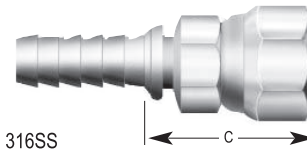

Material: 316SS

Thorburn Part #	Hose ID (in)	Thread Size	Hex Size (in)	Bore Size (in)	Coupling Length (in)	"C" Cut-off (in)
390FJX-4-4S6	1/4	7/16-20	.56	.156	2.13	1.04
390FJX-6-6S6	3/8	9/16-18	.75	.295	2.24	1.22
390FJX-8-8S6	1/2	3/4-16	.88	.406	2.76	1.32
390FJX-12-12S6	3/4	1 1/16-12	1.25	.625	3.39	1.68
390FJX-16-16S6	1	1 5/16-12	1.50	.844	3.63	1.92
390FJX-20-20S6	1 1/4	1 5/8-12	2.00	1.062	4.58	2.28
390FJX-24-24S6	1 1/2	1 7/8-12	2.25	1.312	5.10	2.46
390FJX-32-32S6	2	2 1/2-12	2.88	1.656	6.45	2.92

JIC Solid Male

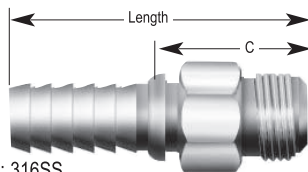

Material: 316SS

Thorburn Part #	Hose ID (in)	Thread Size	Hex Size (in)	Bore Size (in)	Coupling Length (in)	"C" Cut-off (in)
390MJ-4-4S6	1/4	7/16-20	.50	.156	2.23	1.14
390MJ-6-6S6	3/8	9/16-18	.69	.232	2.16	1.15
390MJ-8-8S6	1/2	3/4-16	.88	.406	2.91	1.47
390MJ-12-12S6	3/4	1 1/16-12	1.25	.576	3.48	1.77
390MJ-16-16S6	1	1 5/16-12	1.75	.844	3.71	2.00
390MJ-20-20S6	1 1/4	1 5/8-12	2.00	1.062	4.38	2.08
390MJ-24-24S6	1 1/2	1 7/8-12	2.25	1.312	4.91	2.27
390MJ-32-32S6	2	2 1/2-12	2.63	1.656	6.16	2.63

Female Flat-Face "O" Seal Swivel 45° Bent Tube

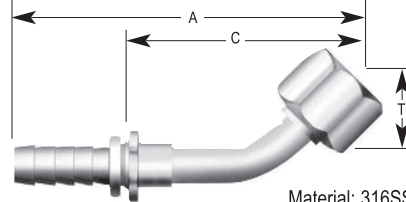

Material: 316SS

Thorburn Part #	Hose ID (in)	Thread Size	Hex A Size (in)	Hex B Size (in)	Bore Size (in)	Coupling Length (in)	"C" Cut-off (in)	"T" Drop Dim. (in)
390FFX45-4-4S6	1/4	9/16-18	11/16	1/2	.156	2.67	1.58	.41
390FFX45-6-6S6	3/8	11/16-16	13/16	5/8	.265	2.95	1.93	.43
390FFX45-8-8S6	1/2	13/16-16	15/16	13/16	.406	3.90	2.47	.59
390FFX45-10-10S6	5/8	1-14	1 1/8	15/16	.500	3.90	2.46	.65
390FFX45-12-12S6	3/4	1 1/16-12	1 3/8	1 1/16	.625	4.57	2.86	.83
390FFX45-16-16S6	1	1 7/16-12	1 5/8	1 3/8	.844	5.31	3.60	.94
390FFX45-20-20S6	1 1/4	1 11/16-12	1 7/8	1 3/4	1.062	6.21	3.91	1.00

JIC Swivel Female 45° Bent Tube

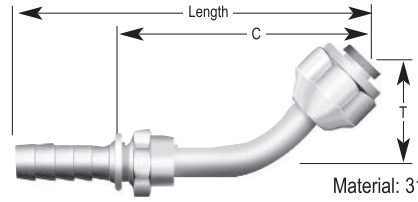

Material: 316SS

Thorburn Part #	Hose ID (in)	Thread Size	Coupling Length (in)	"T" Drop Dim. (in)	"C" Cut-off (in)
390FJX45-4-4S6	1/4	7/16-20	2.79	.47	1.70
390FJX45-6-6S6	3/8	9/16-18	3.12	.56	2.10
390FJX45-8-8S6	1/2	3/4-16	3.98	.78	2.24
390FJX45-12-12S6	3/4	1 1/16-12	4.62	.89	2.91
390FJX45-16-16S6	1	1 5/16-12	5.53	1.06	3.38
390FJX45-20-20S6	1 1/4	1 5/8-12	6.94	1.38	3.80
390FJX45-24-24S6	1 1/2	1 7/8-12	7.15	1.74	4.52

"O" Ring Boss Solid Male

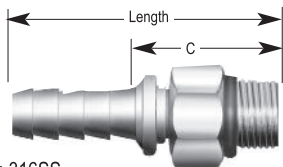

Material: 316SS

Thorburn Part #	Hose ID (in)	Thread Size	Hex Size (in)	Bore Size (in)	Coupling Length (in)	"C" Cut-off (in)
390MB-4-4S6	1/4	7/16-20	.69	.156	2.09	1.00
390MB-6-6S6	3/8	9/16-18	.75	.295	2.10	1.09
390MB-8-8S6	1/2	3/4-16	.88	.406	2.61	.91
390MB-10-10S6	5/8	7/8-14	1.00	.500	2.82	1.10
390MB-12-12S6	3/4	1 1/16-12	1.25	.625	3.27	1.30
390MB-16-16S6	1	1 5/16-12	1.50	.844	3.34	1.28
390MB-20-20S6	1 1/4	1 5/8-12	1.88	1.06	3.90	1.60

Female Flat-Face "O" Seal Swivel 90° Bent Tube

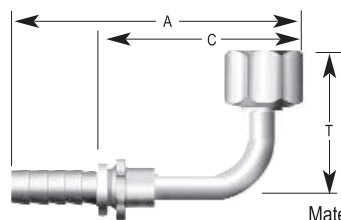

Material: 316SS

Thorburn Part #	Hose ID (in)	Thread Size	Hex A Size (in)	Hex B Size (in)	Bore Size (in)	Coupling Length (in)	"C" Cut-off (in)	"T" Drop Dim. (in)
390FFX90-4-4S6	1/4	9/16-18	11/16	1/2	.156	2.42	1.33	1.26
390FFX90-6-6S6	3/8	11/16-16	13/16	5/8	.265	2.83	1.81	1.51
390FFX90-8-8S6	1/2	13/16-16	15/16	13/16	.406	3.62	2.18	1.62
390FFX90-10-10S6	5/8	1-14	1 1/8	15/16	.500	3.67	2.23	1.85
390FFX90-12-12S6	3/4	1 1/16-12	1 3/8	1 1/16	.625	4.47	2.76	2.28
390FFX90-16-16S6	1	1 7/16-12	1 5/8	1 3/8	.844	5.25	3.54	2.78
390FFX90-20-20S6	1 1/4	1 11/16-12	1 7/8	1 3/4	1.62	6.20	3.90	3.09

JIC Swivel Female 90° Bent Tube

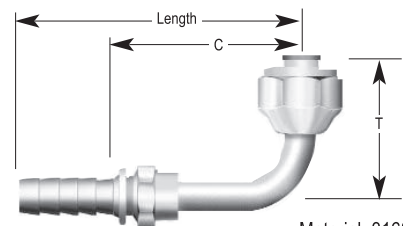

Material: 316SS

Thorburn Part #	Hose ID (in)	Thread Size	Coupling Length (in)	"T" Drop Dim. (in)	"C" Cut-off (in)
390FJX90-4-4S6	1/4	7/16-20	2.53	.88	1.44
390FJX90-6-6S6	3/8	9/16-18	2.91	1.09	1.81
390FJX90-8-8S6	1/2	3/4-16	3.36	1.38	1.93
390FJX90-12-12S6	3/4	1 1/16-12	4.52	2.06	2.81
390FJX90-16-16S6	1	1 5/16-12	5.26	2.62	3.55
390FJX90-20-20S6	1 1/4	1 5/8-12	5.50	3.50	3.70
390FJX90-24-24S6	1 1/2	1 7/8-12	6.94	3.70	4.31

Other sizes available on request.

Dimensions for reference only. Subject to change

Thor-Crimp Carbon Steel Stems & Ferrules

NPTF Solid Male

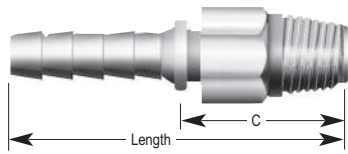

Thorburn Part #	Hose ID (in)	Thread Size	Hex Size (in)	Bore Size (in)	Coupling Length (in)	"C" Cut-off (in)
3TC2-2MP	3/16	1/8-27	.56	.125	2.10	1.01
3TC2-4MP	3/16	1/4-18	.56	.125	2.10	1.01
4TC2-2MP	1/4	1/8-27	.56	.156	2.05	.96
4TC2-4MP	1/4	1/4-18	.56	.156	2.23	1.14
4TC2-6MP	1/4	3/8-18	.75	.156	2.30	1.21
4TC2-8MP	1/4	1/2-14	.88	.156	2.48	1.39
5TC2-4MP	5/16	1/4-18	.63	.232	2.67	1.23
6TC2-4MP	3/8	1/4-18	.75	.295	2.22	1.21
6TC2-6MP	3/8	3/8-18	.69	.295	2.22	1.21
6TC2-8MP	3/8	1/2-14	.88	.295	2.41	1.40
8TC2-6MP	1/2	3/8-18	.88	.406	2.70	1.26
8TC2-8MP	1/2	1/2-14	.88	.406	2.89	1.45
8TC2-12MP	1/2	3/4-14	1.13	.406	2.95	1.51
10TC2-8MP	5/8	1/2-14	.88	.500	2.94	1.50
10TC2-12MP	5/8	3/4-14	1.13	.500	2.94	1.50
12TC2-8MP	3/4	1/2-14	1.13	.500	3.34	1.63
12TC2-12MP	3/4	3/4-14	1.13	.625	3.22	1.51
12TC2-16MP	3/4	1-11/2	1.38	.625	3.53	1.82
14TC2-16MP	7/8	1-11/2	1.38	.750	3.06	1.81
16TC2-12MP	1	3/4-14	1.38	.718	3.50	1.79
16TC2-16MP	1	1-11/2	1.38	.844	3.69	1.98
20TC2-20MP	1 1/4	1 1/4-11 1/2	1.75	1.062	4.39	2.09
24TC2-24MP	1 1/2	1 1/2-11 1/2	2.00	1.312	4.82	2.18
32TC2-32MP	2	2-11 1/2	2.50	1.656	5.86	2.33

NPTF Swivel Male

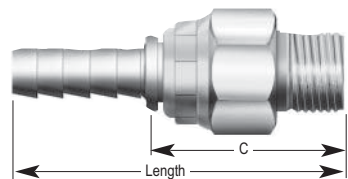

Thorburn Part #	Hose ID (in)	Thread Size	Hex Size (in)	Bore Size (in)	Coupling Length (in)	"C" Cut-off (in)
3TC2-2MPX	3/16	1/8-27	.50	.125	2.00	1.31
4TC2-4MPX	1/4	1/4-18	.69	.156	2.63	1.54
4TC2-6MPX	1/4	3/8-18	.69	.156	2.63	1.54
4TC2-8MPX	1/4	1/2-14	.88	.156	2.97	1.87
6TC2-4MPX	3/8	1/4-18	.88	.295	2.75	1.74
6TC2-6MPX	3/8	3/8-18	.88	.295	2.73	1.72
6TC2-8MPX	3/8	1/2-14	.88	.295	2.89	1.88
8TC2-6MPX	1/2	3/8-18	.88	.344	3.19	1.76
8TC2-8MPX	1/2	1/2-14	1.00	.406	3.38	1.94
10TC2-12MPX	5/8	3/4-14	1.31	.500	3.44	2.00
12TC2-8MPX	3/4	1/2-14	1.00	.500	3.66	1.95
12TC2-12MPX	3/4	3/4-14	1.31	.625	3.71	2.00
16TC2-16MPX	1	1-11/2	1.62	.844	4.18	2.47

NPTF Swivel Male 90°

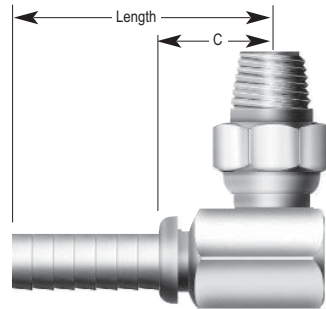

Thorburn Part #	Hose ID (in)	Thread Size	Hex Size (in)	Bore Size (in)	Coupling Length (in)	"C" Cut-off (in)
4TC2-4MPX90	1/4	1/4-18	.69	.156	1.79	.70
4TC2-6MPX90	1/4	3/8-18	.69	.156	1.79	.70
6TC2-4MPX90	3/8	1/4-18	.88	.296	1.84	.83
6TC2-6MPX90	3/8	3/8-18	.88	.296	1.84	.83
6TC2-8MPX90	3/8	1/2-14	1.00	.296	1.84	.83
8TC2-8MPX90	1/2	1/2-14	1.00	.406	2.26	1.07
8TC2-12MPX90	3/4	3/4-14	1.31	.625	2.91	1.20
8TC2-8MPX90L	1/2	1/2-14	1.00	.406	3.51	2.07
12TC2-12MPX90L	3/4	3/4-14	1.31	.625	3.66	1.95

JIC Solid Male

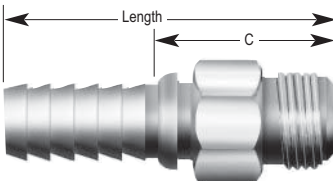

Thorburn Part #	Hose ID (in)	Thread Size	Hex Size (in)	Bore Size (in)	Coupling Length (in)	"C" Cut-off (in)
3TC2-4MJ	3/16	7/16-20	.56	.125	2.10	1.01
4TC2-4MJ	1/4	7/16-20	.50	.156	2.23	1.14
4TC2-5MJ	1/4	1/2-20	.56	.156	2.30	1.21
4TC2-6MJ	1/4	9/16-18	.56	.156	2.61	1.52
5TC2-6MJ	5/16	9/16-18	.63	.232	2.67	1.23
6TC2-6MJ	3/8	9/16-18	.69	.232	2.16	1.15
6TC2-8MJ	3/8	3/4-16	.81	.295	2.32	1.31
6TC2-10MJ	3/8	7/8-14	.88	.295	2.41	1.40
8TC2-8MJ	1/2	3/8-18	.88	.406	2.80	1.36
8TC2-10MJ	1/2	1/2-14	.88	.406	2.91	1.47
8TC2-12MJ	1/2	3/4-14	1.13	.406	3.18	1.74
10TC2-8MJ	5/8	1/2-14	1.13	.500	3.09	1.65
10TC2-10MJ	5/8	1/2-14	1.13	.500	3.09	1.65
10TC2-12MJ	5/8	3/4-14	1.13	.500	3.19	1.75
12TC2-12MJ	3/4	1 1/8-12	1.13	.609	3.41	1.70
12TC2-14MJ	3/4	1 3/8-12	1.25	.576	3.48	1.77
12TC2-16MJ	3/4	1 5/8-12	1.38	.625	3.56	1.85
16TC2-16MJ	1	1 5/8-12	1.38	.844	3.66	1.95
16TC2-20MJ	1	1 5/8-12	1.75	.844	3.71	2.00
20TC2-20MJ	1 1/4	1 5/8-12	1.75	1.062	4.38	2.08
20TC2-24MJ	1 1/4	1 7/8-12	2.00	1.062	4.56	2.26
24TC2-24MJ	1 1/2	1 7/8-12	2.00	1.312	4.91	2.27
32TC2-32MJ	2	2 1/2-12	2.63	1.656	6.16	2.63

NPTF Solid Female

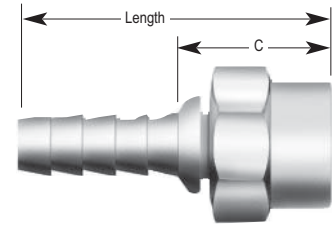

Thorburn Part #	Hose ID (in)	Thread Size	Hex Size (in)	Bore Size (in)	Coupling Length (in)	"C" Cut-off (in)
3TC2-2FP	3/16	1/8-27	.56	.125	2.04	.95
4TC2-2FP	1/4	1/8-27	.69	.156	1.73	.64
4TC2-4FP	1/4	1/4-18	.69	.156	2.38	1.29
4TC2-6FP	1/4	3/8-18	.81	.156	2.04	.95
6TC2-4FP	3/8	1/4-18	.81	.265	1.97	.96
6TC2-6FP	3/8	3/8-18	.88	.265	1.97	.96
6TC2-8FP	3/8	1/2-14	1.00	.265	2.49	1.48
8TC2-6FP	1/2	3/8-18	.88	.406	2.57	1.13
8TC2-8FP	1/2	1/2-14	1.00	.406	2.70	1.26
12TC2-12FP	3/4	3/4-14	1.25	.625	3.16	1.45

NPTF Swivel Female

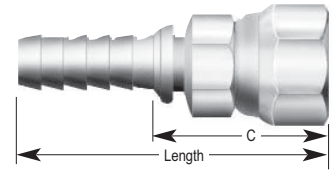

Thorburn Part #	Hose ID (in)	Thread Size	Hex Size (in)	"C" Cut-off (in)
4TC2-4FPX	1/4	1/4-18	.69	1.24
6TC2-6FPX	3/8	3/8-18	.88	1.28
8TC2-8FPX	1/2	1/2-14	1.00	1.35
12TC2-12FPX	3/4	3/4-14	1.25	1.75
16TC2-16FPX	1	1-11/2	1.50	1.90

JIC Swivel Female

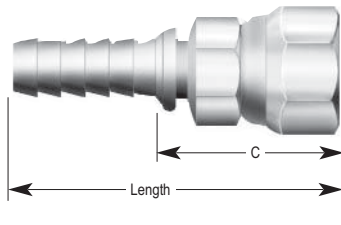

JIC Swivel Female 45° Bent Tube

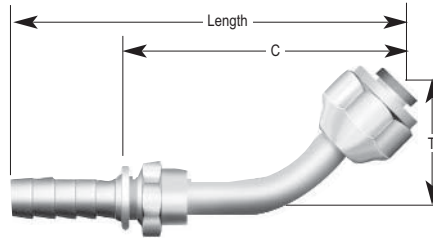

JIC Swivel Female 90° Bent Tube

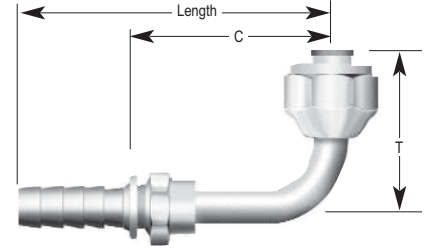

Thorburn Part #	Hose ID (in)	Thread Size	Hex Size (in)	Bore Size (in)	Coupling Length (in)	"C" Cut-off (in)
4TC2-4FJX	1/4	7/16-20	.56	.156	2.13	1.04
4TC2-5FJX	1/4	1/2-20	.69	.156	2.28	1.18
4TC2-6FJX	1/4	9/16-18	.75	.156	2.28	1.18
5TC2-5FJX	5/16	1/2-20	.69	.232	2.25	1.23
5TC2-6FJX	5/16	9/16-18	.75	.232	2.24	1.22
6TC2-5FJX	3/8	1/2-20	.69	.270	2.14	1.12
6TC2-6FJX	3/8	9/16-18	.75	.295	2.24	1.22
6TC2-8FJX	3/8	3/4-16	.88	.295	2.35	1.33
6TC2-10FJX	3/8	7/8-14	1.06	.295	2.51	1.49
8TC2-6FJX	1/2	9/16-18	.75	.406	2.62	1.18
8TC2-8FJX	1/2	3/4-16	.88	.406	2.76	1.32
8TC2-10FJX	1/2	7/8-14	1.06	.406	2.98	1.54
8TC2-12FJX	1/2	1 1/16-12	1.25	.406	3.10	1.66
10TC2-8FJX	5/8	3/4-16	1.00	.468	2.85	1.41
10TC2-10FJX	5/8	7/8-14	1.06	.500	3.04	1.60
10TC2-12FJX	5/8	1 1/16-12	1.25	.500	3.12	1.68
10TC2-14FJX	5/8	1 3/16-12	1.38	.500	3.25	1.81
12TC2-10FJX	3/4	7/8-14	1.06	.594	3.20	1.49
12TC2-12FJX	3/4	1 1/16-12	1.25	.625	3.39	1.68
12TC2-14FJX	3/4	1 3/16-12	1.38	.625	3.56	1.85
12TC2-16FJX	3/4	1 5/16-12	1.50	.625	3.51	1.80
16TC2-12FJX	1	1 1/16-12	1.25	.718	3.44	1.73
16TC2-14FJX	1	1 3/16-12	1.38	.844	3.47	1.76
16TC2-16FJX	1	1 5/16-12	1.50	.844	3.63	1.92
16TC2-20FJX	1	1 5/8-12	2.00	.844	3.79	2.08
20TC2-20FJX	1 1/4	1 5/8-12	2.00	1.062	4.58	2.28
20TC2-24FJX	1 1/4	1 7/8-12	2.00	1.06	4.85	2.55
24TC2-24FJX	1 1/2	1 7/8-12	2.25	1.312	5.10	2.46
32TC2-32FJX	2	2 1/2-12	2.88	1.656	6.45	2.92

Thorburn Part #	Hose ID (in)	Thread Size	"T" Drop Dim. (in)	"C" Cut-off (in)
4TC2-4FJX45	1/4	7/16-20	TBA	1.70
4TC2-5FJX45	1/4	1/2-20	TBA	1.80
4TC2-6FJX45	1/4	9/16-18	TBA	2.02
5TC2-5FJX45	5/16	1/2-20	TBA	1.88
5TC2-6FJX45	5/16	9/16-18	TBA	2.10
6TC2-6FJX45	3/8	9/16-18	TBA	2.10
6TC2-8FJX45	3/8	3/4-16	TBA	2.45
8TC2-8FJX45	1/2	3/4-16	TBA	2.24
8TC2-10FJX45	1/2	7/8-14	TBA	2.58
10TC2-10FJX45	5/8	7/8-14	TBA	2.58
10TC2-12FJX45	5/8	1 1/16-12	TBA	3.08
12TC2-10FJX45	3/4	7/8-14	TBA	2.80
12TC2-12FJX45	3/4	1 1/16-12	TBA	2.91
12TC2-16FJX45	3/4	1 5/16-12	TBA	3.07
16TC2-16FJX45	1	1 5/16-12	TBA	3.82
20TC2-20FJX45	1 1/4	1 5/8-12	TBA	5.64

Thorburn Part #	Hose ID (in)	Thread Size	"T" Drop Dim. (in)	"C" Cut-off (in)
3TC2-4FJX90	3/16	7/16-20	TBA	1.45
4TC2-4FJX90	1/4	7/16-20	TBA	1.44
4TC2-5FJX90	1/4	1/2-10	TBA	1.52
4TC2-6FJX90	1/4	9/16-18	TBA	1.73
5TC2-6FJX90	5/16	9/16-19	TBA	1.81
6TC2-6FJX90	3/8	9/16-18	TBA	1.81
6TC2-8FJX90	3/8	3/4-16	TBA	2.14
8TC2-8FJX90	1/2	3/4-16	TBA	1.93
8TC2-10FJX90	1/2	7/8-14	TBA	2.19
10TC2-10FJX90	5/8	7/8-14	TBA	2.19
10TC2-12FJX90	5/8	1 1/16-12	TBA	2.69
12TC2-12FJX90	3/4	1 1/16-12	TBA	2.81
16TC2-16FJX90	1	1 5/16-12	TBA	3.55
16TC2-20FJX90	1	1 5/8-12	TBA	3.80
20TC2-20FJX90	1 1/4	1 5/8-12	TBA	3.20

Length available on request

“O” Ring Boss Solid Male

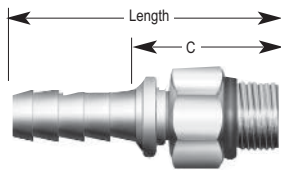

Thorburn Part #	Hose ID (in)	Thread Size	Hex Size (in)	Bore Size (in)	Coupling Length (in)	“C” Cut-off (in)
4TC2-4MB	1/4	7/16-20	.69	.156	2.09	1.00
4TC2-5MB	1/4	1/2-20	.56	.156	2.03	.74
4TC2-6MB	1/4	9/16-18	.69	.156	2.19	1.10
6TC2-6MB	3/8	9/16-18	.75	.295	2.10	1.09
6TC2-8MB	3/8	3/4-16	.88	.295	2.10	1.09
6TC2-10MB	3/8	7/8-14	1.00	.295	2.16	1.15
6TC2-12MB	3/8	1 1/16-12	1.25	.295	2.25	1.24
8TC2-8MB	1/2	3/4-16	.88	.406	2.61	.91
8TC2-10MB	1/2	7/8-14	1.00	.406	2.64	.94
8TC2-12MB	1/2	1 1/16-12	1.25	.406	2.91	1.47
10TC2-8MB	5/8	3/4-16	1.00	.500	2.76	1.05
10TC2-10MB	5/8	7/8-14	1.00	.500	2.82	1.10
10TC2-12MB	5/8	1 1/16-12	1.25	.500	2.91	1.20
12TC2-12MB	3/4	1 1/16-12	1.25	.625	3.27	1.30
12TC2-14MB	3/4	1 3/16-12	1.38	.625	3.18	1.47
12TC2-16MB	3/4	1 5/16-12	1.50	.625	3.06	1.96
16TC2-14MB	1	1 3/16-12	1.50	.844	3.28	1.58
16TC2-16MB	1	1 5/16-12	1.50	.844	3.34	1.28
20TC2-20MB	1 1/4	1 5/8-12	1.88	1.06	3.90	1.60

“O” Ring Boss Swivel Male

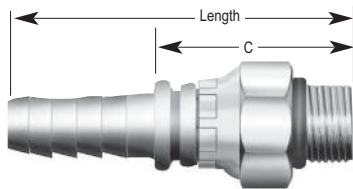

Thorburn Part #	Hose ID (in)	Thread Size	Hex Size (in)	Bore Size (in)	Coupling Length (in)	“C” Cut-off (in)
4TC2-6MBX	1/4	9/16-18	.88	.160	2.69	1.60
6TC2-6MBX	3/8	9/16-18	.89	.265	2.61	1.60
6TC2-8MBX	3/8	3/4-16	.88	.295	2.50	1.62
6TC2-10MBX	3/8	7/8-14	1.00	.295	2.59	1.68
8TC2-8MBX	1/2	3/4-16	1.00	.406	3.07	1.63
8TC2-10MBX	1/2	7/8-14	1.00	.406	3.13	1.69
12TC2-12MBX	3/4	1 1/16-12	1.31	.625	3.68	1.98
12TC2-14MBX	3/4	1 3/16-12	1.31	.625	3.56	1.85

Non-Stock. Minimum Quantity Will Apply

“O” Ring Boss Swivel Male 45°

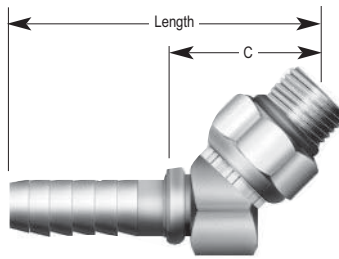

Thorburn Part #	Hose ID (in)	Thread Size	Hex Size (in)	Bore Size (in)	Coupling Length (in)	“C” Cut-off (in)
6TC2-6MBX45	3/8	9/16-18	.88	.270	3.01	2.00
6TC2-8MBX45	3/8	3/4-16	1.00	.270	2.98	1.97
8TC2-8MBX45	1/2	3/4-16	1.00	.410	2.99	1.55
8TC2-10MBX45	1/2	7/8-14	1.00	.410	3.35	1.91

Price available upon request
Non-Stock. Minimum Quantity Will Apply

“O” Ring Boss Swivel Male 90°

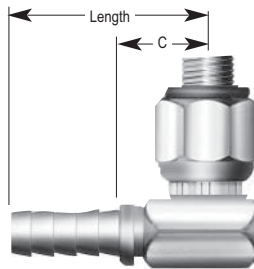

Thorburn Part #	Hose ID (in)	Thread Size	Hex Size (in)	Bore Size (in)	Coupling Length (in)	“C” Cut-off (in)
4TC2-6MBX90	1/4	9/16-18	.88	.156	1.79	.70
6TC2-6MBX90	3/8	9/16-18	.88	.296	1.84	.83
6TC2-8MBX90	3/8	3/4-16	1.00	.296	1.84	.83
6TC2-10MBX90	3/8	7/8-14	1.00	.296	1.84	.83
8TC2-8MBX90	1/2	3/4-16	1.00	.406	2.51	1.07
8TC2-10MBX90	1/2	7/8-14	1.00	.406	2.51	1.07
8TC2-12MBX90	1/2	1 1/16-12	1.31	.406	2.51	1.06
10TC2-10MBX90	5/8	7/8-14	1.00	.500	2.39	.95
12TC2-12MBX90	3/4	1 1/16-12	1.31	.625	2.91	1.20
8TC2-8MBX90L	1/2	3/4-16	1.00	.406	3.26	1.82
8TC2-10MBX90L	1/2	7/8-14	1.00	.406	3.26	1.82
8TC2-12MBX90L	1/2	1 1/16-12	1.31	.406	3.76	2.31
10TC2-10MBX90L	5/8	7/8-14	1.00	.500	3.39	1.95
12TC2-12MBX90L	3/4	1 1/16-12	1.31	.625	3.66	1.95

Price available upon request
Non-Stock. Minimum Quantity Will Apply

“O” Ring Flange Straight (Code 61- SAE J518)

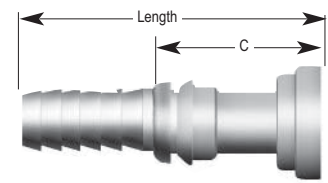

Thorburn Part #	Hose ID (in)	Norm. Fig. Dia. (in)	“M” Fig. Dia. (in)	Coupling Length (in)	“C” Cut-off (in)
8TC2-8FL	1/2	1/2	1 3/16	3.29	1.86
8TC2-12FL	1/2	3/4	1 1/2	3.29	1.86
12TC2-8FL	3/4	3/4	1 1/2	3.74	2.04
12TC2-12FL	3/4	1	1 3/4	3.74	2.04
16TC2-12FL	1	1	1 3/4	3.62	1.91
16TC2-20FL	1	1	1 3/4	3.62	1.91
16TC2-24FL	1	1 1/2	2 3/8	3.62	1.91
20TC2-20FL	1 1/4	1 1/4	2	4.63	2.33
20TC2-24FL	1 1/4	1 1/2	2 3/8	4.63	2.33
24TC2-24FL	1 1/2	1 1/2	2 3/8	4.94	2.30
24TC2-32FL	1 1/2	2	2 3/16	4.94	2.30
32TC2-32FL	2	2	2 3/16	6.08	2.54
32TC2-40FL	2	2 1/2	3 5/16	6.07	2.54

*See Adapter section for Flange Halves.

“O” Seal Flange 45° Bent Tube (Code 61- SAE J518)

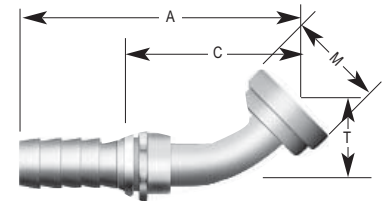

Thorburn Part #	Hose ID (in)	Norm. Fig. Dia. (in)	“M” Fig. Dia. (in)	“T” Drop Dim. (in)	“A” Dim. (in)	“C” Cut-off (in)
8TC2-8FL45	1/2	1/2	1 3/16	TBA	3.66	2.23
8TC2-12FL45	1/2	3/4	1 1/2	TBA	3.66	2.23
12TC2-12FL45	3/4	3/4	1 1/2	TBA	4.42	2.72
12TC2-16FL45	3/4	1	1 3/4	TBA	4.42	2.72
16TC2-16FL45	1	1	1 3/4	TBA	4.62	2.91
16TC2-20FL45	1	1 1/4	2	TBA	4.62	2.91
20TC2-20FL45	1 1/4	1 1/4	2	TBA	5.54	3.24
20TC2-24FL45	1 1/4	1 1/2	2 3/8	TBA	5.54	3.24
24TC2-24FL45	1 1/2	1 1/2	2 3/8	TBA	6.53	3.89
24TC2-32FL45	1 1/2	2	2 3/16	TBA	6.53	3.89
32TC2-32FL45	2	2	2 3/16	TBA	8.52	4.98

Dimensions for reference only. Subject to change

“O” Ring Flange 90° Bent Tube

(Code 61-SAE J518)

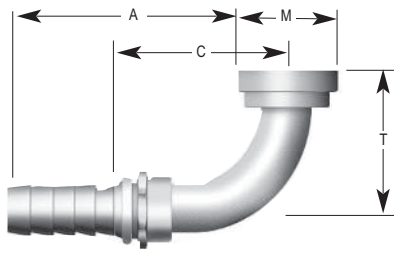

Thorburn Part #	Hose ID (in)	Nom. Fig. Dia. (in)	“M” Fig. Dia. (in)	“T” Drop Dim. (in)	“A” Dim. (in)	“C” Cut-off (in)
8TC2-8FL90	1/2	1/2	1 3/16	TBA	3.54	2.11
8TC2-12FL90	1/2	3/4	1 1/2	TBA	3.54	2.11
10TC2-10FL90	5/8	3/4	1 1/2	TBA	3.97	2.53
12TC2-12FL90	3/4	3/4	1 1/2	TBA	4.14	2.44
12TC2-16FL90	3/4	1	1 3/4	TBA	4.14	2.44
12TC2-20FL90	3/4	1	2	TBA	4.14	2.44
16TC2-16FL90	1	1	1 3/4	TBA	4.56	2.85
16TC2-20FL90	1	1 1/4	2	TBA	4.56	2.85
16TC2-24FL90	1	1 1/2	2 3/8	TBA	4.56	2.85
20TC2-20FL90	1 1/4	1 1/4	2	TBA	5.38	3.08
20TC2-20FL90	1 1/4	1 1/4	2	TBA	5.38	3.08
20TC2-24FL90	1 1/4	1 1/2	2 3/8	TBA	5.38	3.08
24TC2-24FL90	1 1/2	1 1/2	2 3/8	TBA	6.19	3.55
24TC2-24FL90	1 1/2	1 1/2	2 3/8	TBA	6.19	3.55
24TC2-32FL90	1 1/2	2	2 3/16	TBA	6.19	3.55
32TC2-32FL90	2	2	2 3/16	TBA	8.52	4.98

*See Adapter section for Flange Halves.

“O” Ring Flange Straight

(Code 62-SAE J518)

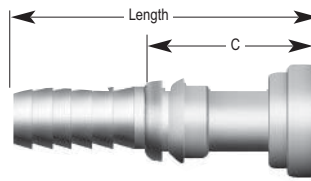

Thorburn Part #	Hose ID (in)	Nom. Fig. Dia. (in)	“M” Fig. Dia. (in)	Coupling Length (in)	“C” Cut-off (in)
8TC2-8FLH	1/2	1/2	1.25	3.66	2.19
8TC2-12FLH	1/2	3/4	1.63	3.66	2.19
10TC2-8FLH	5/8	1/2	1.25	4.29	2.31
10TC2-12FLH	5/8	3/4	1.63	4.29	2.31
12TC2-12FLH	3/4	3/4	1.63	4.49	2.48
12TC2-16FLH	3/4	1	1.88	4.49	2.48
16TC2-12FLH	1	3/4	1.63	5.08	2.86
16TC2-16FLH	1	1	1.88	4.92	2.70
16TC2-20FLH	1	1 1/4	2.13	4.92	2.69
20TC2-16FLH	1 1/4	1	1.88	6.42	3.62
20TC2-20FLH	1 1/4	1 1/4	2.13	5.75	2.95
20TC2-24FLH	1 1/4	1 1/2	2.50	6.30	3.50

*See Adapter section for Flange Halves.

“O” Seal Flange 45° Bent Tube

(Code 62-SAE J518)

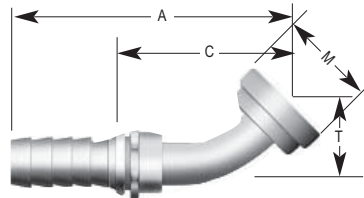

Thorburn Part #	Hose ID (in)	Nom. Fig. Dia. (in)	“M” Fig. Dia. (in)	“T” Drop Dim. (in)	“A” Dim. (in)	“C” Cut-off (in)
8TC2-8FLH45	1/2	1/2	1.25	TBA	3.66	2.23
8TC2-12FLH45	1/2	3/4	1.63	TBA	3.66	2.23
10TC2-12FLH45	5/8	3/4	1.63	TBA	4.42	2.72
12TC2-12FLH45	3/4	1	1.63	TBA	4.42	2.72
12TC2-16FLH45	3/4	1	1.88	TBA	4.62	2.91
16TC2-16FLH45	1	1 1/4	1.88	TBA	4.62	2.91
16TC2-20FLH45	1	1 1/4	2.13	TBA	5.54	3.24
20TC2-20FLH45	1 1/4	1 1/2	2.13	TBA	5.54	3.24
20TC2-24FLH45	1 1/4	1 1/2	2.50	TBA	6.53	3.89

“O” Ring Flange 90° Bent Tube

(Code 62-SAE J518)

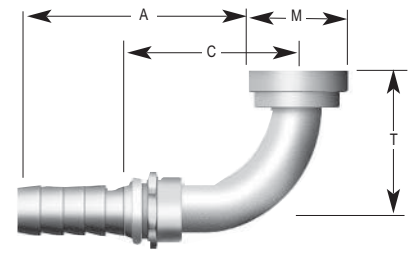

Thorburn Part #	Hose ID (in)	Nom. Fig. Dia. (in)	“M” Fig. Dia. (in)	“T” Drop Dim. (in)	“A” Dim. (in)	“C” Cut-off (in)
8TC2-8FLH90	1/2	1/2	1 3/16	TBA	3.54	2.11
8TC2-12FLH90	1/2	3/4	1 1/2	TBA	3.54	2.11
10TC2-10FLH90	5/8	3/4	1 1/2	TBA	3.97	2.53
12TC2-12FLH90	3/4	3/4	1 1/2	TBA	4.14	2.44
12TC2-16FLH90	3/4	1	1 3/4	TBA	4.14	2.44
12TC2-20FLH90	3/4	1	2	TBA	4.14	2.44
16TC2-16FLH90	1	1	1 3/4	TBA	4.56	2.85
16TC2-20FLH90	1	1 1/4	2	TBA	4.56	2.85
16TC2-24FLH90	1	1 1/2	2 3/8	TBA	4.56	2.85
20TC2-20FLH90	1 1/4	1 1/4	2	TBA	5.38	3.08
20TC2-20FLH90	1 1/4	1 1/4	2	TBA	5.38	3.08
20TC2-24FLH90	1 1/4	1 1/2	2 3/8	TBA	5.38	3.08
24TC2-24FLH90	1 1/2	1 1/2	2 3/8	TBA	6.19	3.55
24TC2-24FLH90	1 1/2	1 1/2	2 3/8	TBA	6.19	3.55
24TC2-32FLH90	1 1/2	2	2 3/16	TBA	6.19	3.55
32TC2-32FLH90	2	2	2 3/16	TBA	8.52	4.98

*See Adapter section for Flange Halves.

Male Flat-Face "O" Ring

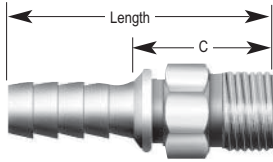

Thorburn Part #	Hose ID (in)	Thread Size	Hex Size (in)	Bore Size (in)	"A" Coupling Lgth (in)	"C" Cut-off (in)
4TC2-4MFF	1/4	9/16-18	5/8	.156	1.96	.87
6TC2-6MFF	3/8	11/16-16	3/4	.265	1.98	.96
6TC2-8MFF	3/8	13/16-16	7/8	.270	2.12	1.10
8TC2-8MFF	1/2	13/16-16	7/8	.406	2.56	1.13
10TC2-10MFF	5/8	1-14	1 1/16	.500	2.72	1.29
12TC2-12MFF	3/4	1 1/16-12	1 1/4	.625	3.05	1.35
16TC2-16MFF	1	1 7/16-12	1 1/2	.844	3.17	1.47
20TC2-20MFF	1 1/4	1 11/16-12	1 3/4	1.062	3.83	1.53
24TC2-24MFF	1 1/2	2-12	2 1/8	1.31	4.18	1.54

Price available upon request

SAE Male Flareless

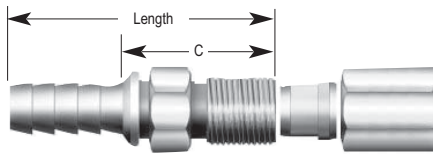

Thorburn Part #	Hose ID (in)	Thread Size	Tube OD (in)	Hex Nut Size (in) A	Stem Hex Size (in) D	Bore size (in) B	Ref. Stem Lng. (in)	"C" Cut-off (in)
4TC2-4MFA	1/4	7/16-20	1/4	9/16	1/2	.156	2.02	.94
4TC2-5MFA	1/4	1/2-20	5/16	5/8	9/16	.156	2.02	.94
6TC2-4MFA	3/8	7/16-20	1/4	9/16	5/8	.265	1.97	.95
6TC2-5MFA	3/8	1/2-16	5/16	5/8	5/8	.265	1.97	.95
6TC2-6MFA	3/8	9/16-18	3/8	11/16	5/8	.265	1.98	.97
6TC2-8MFA	3/8	3/4-16	1/2	7/8	13/16	.265	2.20	1.18
8TC2-8MFA	1/2	3/4-16	1/2	7/8	13/16	.406	2.68	1.24
8TC2-10MFA	1/2	7/8-14	5/8	1	15/16	.406	2.74	1.30
12TC2-12MFA	3/4	1 1/16-12	3/4	1 1/4	1 1/8	.625	3.16	1.45
16TC2-16MFA	1	1 15/16-12	1	1 1/2	1 3/8	.844	3.26	1.55

Female Flat-Face "O" Seal Swivel 90° Bent Tube

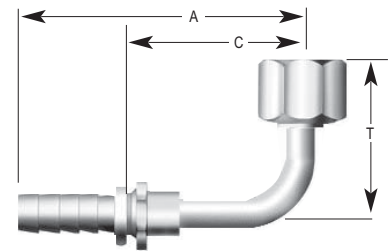

Thorburn Part #	Hose ID (in)	Thread Size	Hex A Size (in)	Hex B Size (in)	Bore Size (in)	Coupling Lgth (in)	"C" Cut-off (in)	"T" Drop Dim.
4TC2-4FFX90S	1/4	9/16-18	11/16	1/2	.156	2.42	1.33	TBA
6TC2-6FFX90S	3/8	11/16-16	13/16	5/8	.265	2.83	1.81	TBA
8TC2-8FFX90S	1/2	13/16-16	15/16	13/16	.406	3.62	2.18	TBA
10TC2-10FFX90S	5/8	1-14	1 1/8	15/16	.500	3.67	2.23	TBA
12TC2-12FFX90S	3/4	1 3/16-12	1 3/8	1 1/8	.625	4.47	2.76	TBA
16TC2-16FFX90S	1	1 7/16-12	1 5/8	1 3/8	.844	5.25	3.54	TBA
20TC2-20FFX90S	1 1/4	1 11/16-12	1 7/8	1 3/4	1.062	6.20	3.90	TBA

Female Flat-Face "O" Seal Swivel Straight

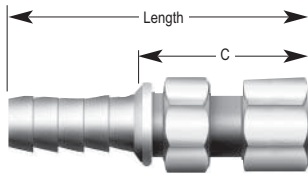

Thorburn Part #	Hose ID (in)	Thread Size	Hex A Size (in)	Hex B Size (in)	Bore Size (in)	Coupling Length (in)	"C" Cut-off (in)
4TC2-4FFX	1/4	9/16-18	11/16	1/2	.156	2.32	1.23
4TC2-6FFX	1/4	11/16-18	13/16	1/2	.156	2.54	1.45
6TC2-6FFX	3/8	11/16-16	13/16	5/8	.265	2.47	1.46
6TC2-8FFX	3/8	13/16-16	15/16	5/8	.265	2.62	1.60
8TC2-8FFX	1/2	13/16-16	15/16	13/16	.406	3.10	1.66
8TC2-10FFX	1/2	1-14	1 1/8	13/16	.406	3.29	1.85
10TC2-10FFX	5/8	1-14	1 1/8	15/16	.500	3.25	1.81
10TC2-12FFX	5/8	1 3/16-12	1 1/8	15/16	.500	3.25	1.81
12TC2-10FFX	3/4	1-14	1 1/8	1 1/16	.500	3.46	1.75
12TC2-12FFX	3/4	1 3/16-12	1 1/8	1 1/16	.625	3.56	1.85
12TC2-16FFX	3/4	1 7/16-12	1 5/8	1 1/8	.625	3.73	2.02
16TC2-16FFX	1	1 7/16-12	1 5/8	1 3/8	.844	4.01	2.30
16TC2-20FFX	1	1 11/16-12	1 7/8	1 3/8	.844	4.00	2.29
20TC2-20FFX	1 1/4	1 11/16-12	1 7/8	1 3/4	1.062	4.51	2.21

Female Flat-Face "O" Seal Swivel 45° Bent Tube

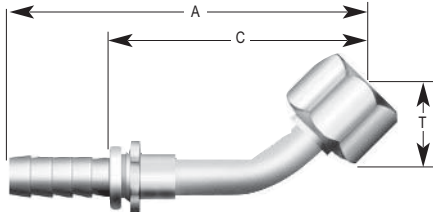

Thorburn Part #	Hose ID (in)	Thread Size	Hex A Size (in)	Hex B Size (in)	Bore Size (in)	Coupling Lgth (in)	"C" Cut-off (in)	"T" Drop Dim.
4TC2-4FFX45	1/4	9/16-18	11/16	1/2	.156	2.67	1.58	TBA
6TC2-6FFX45	3/8	11/16-16	13/16	5/8	.265	2.95	1.93	TBA
8TC2-8FFX45	1/2	13/16-16	15/16	13/16	.406	3.90	2.47	TBA
10TC2-10FFX45	5/8	1-14	1 1/8	15/16	.500	3.90	2.46	TBA
12TC2-12FFX45	3/4	1 3/16-12	1 3/8	1 1/8	.625	4.57	2.86	TBA
16TC2-16FFX45	1	1 7/16-12	1 5/8	1 3/8	.844	5.31	3.60	TBA
20TC2-20FFX45	1 1/4	1 11/16-12	1 7/8	1 3/4	1.062	6.21	3.91	TBA

Nut



Thorburn Part #	Tube Size (in)	Thread Size (in)	Hex Size (in)
4TC2FFN	1/4	7/16-20	5/8
5TC2FFN	5/16	1/2-20	5/8
6TC2FFN	3/8	9/16-18	11/16
8TC2FFN	1/2	3/4-16	7/8
10TC2FFN	5/8	7/8-14	1
12TC2FFN	3/4	1 1/16-12	1 1/4
16TC2FFN	1	1 5/16-12	1 1/2

Sleeve



Thorburn Part #	Tube Size (in)
4TC2FFS	1/4
5TC2FFS	5/16
6TC2FFS	3/8
8TC2FFS	1/2
10TC2FFS	5/8
12TC2FFS	3/4
16TC2FFS	1

British Threading

BSPB Solid Male

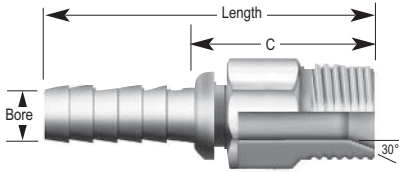

Thorburn Part #	Hose ID (in)	Thread Size	Hex Size (in)	Bore Size (in)	Coupling Length (in)	"C" Cut-off (in)
4TC2-4MBSPP	1/4	1/4-10	5/8	.156	2.26	1.17
6TC2-6MBSPP	3/8	3/8-18	3/4	.265	2.20	1.18
6TC2-8MBSPP	3/8	3/8-16	7/8	.27	2.28	1.26
8TC2-8MBSPP	1/2	1/2-16	7/8	.406	2.76	1.32
10TC2-10MBSPP	5/8	5/8-14	1	.500	2.82	1.38
12TC2-12MBSPP	3/4	3/4-12	1 1/8	.625	3.21	1.50
16TC2-16MBSPP	1	1-12	1 1/2	.844	3.60	1.89
20TC2-20MBSPP	1 1/4	1 1/4-12	1 3/4	1.062	4.13	1.83
6TC2-6MBSPPOR	3/8	3/8-18	7/8	.27	2.20	1.18

+Includes "O" ring.

BSPB Swivel Female

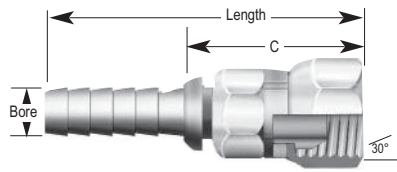

Thorburn Part #	Hose ID (in)	Thread Size	Nut Hex Size (in)	Stem Hex Size (in)	Bore Size (in)	Coupling Length (in)	"C" Cut-off (in)
4TC2-4FBSPPX	1/4	1/4-19	3/4	1/2	.156	2.28	1.18
4TC2-6FBSPPX	1/4	3/8-19	7/8	5/8	.16	2.29	1.20
5TC2-6FBSPPX	5/16	3/8-19	7/8	5/8	.23	2.22	1.20
6TC2-6FBSPPX	3/8	3/8-19	7/8	5/8	.265	2.25	1.23
6TC2-8FBSPPX	3/8	1/2-14	1	13/16	.27	2.28	1.26
8TC2-8FBSPPX	1/2	1/2-14	1	13/16	.406	2.79	1.35
10TC2-10FBSPPX	5/8	5/8-14	1 1/8	15/16	.500	2.96	1.52
12TC2-12FBSPPX	3/4	3/4-14	1 1/4	1 1/16	.625	3.35	1.64
16TC2-16FBSPPX	1	1-11	1 1/2	1 3/8	.844	3.54	1.83
20TC2-20FBSPPX	1 1/4	1 1/4-11	1 7/8	1 3/4	1.062	4.43	2.13

BSPB Swivel Female 90° Bent Tube

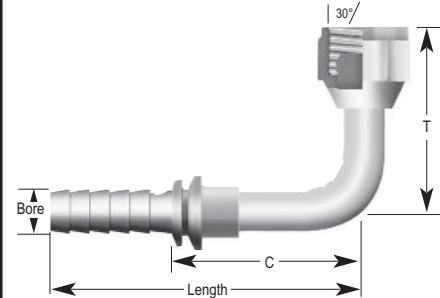

Thorburn Part #	Hose ID (in)	Thread Size	Nut Hex Size (in)	Stem Hex Size (in)	"T" Drop Dim. (in)	Coupling Length (in)	"C" Cut-off (in)
4TC2-4FBSPPX90	1/4	1/4-19	3/4	1/2	TBA	2.54	1.45
6TC2-6FBSPPX90	3/8	3/8-19	7/8	5/8	TBA	2.75	1.73
6TC2-8FBSPPX90	3/8	1/2-14	1	5/8	TBA	3.22	2.20
8TC2-8FBSPPX90	1/2	1/2-14	1	13/16	TBA	3.70	2.26
10TC2-10FBSPPX90	5/8	5/8-14	1 1/8	15/16	TBA	4.08	2.64
12TC2-12FBSPPX90	3/4	3/4-14	1 1/4	1 1/16	TBA	4.73	3.02
16TC2-16FBSPPX90	1	1-11	1 1/2	1 3/8	TBA	5.63	3.93
20TC2-20FBSPPX90	1 1/4	1 1/4-11	1 7/8	1 3/4	TBA	5.95	3.65

Male BSPT Tapered

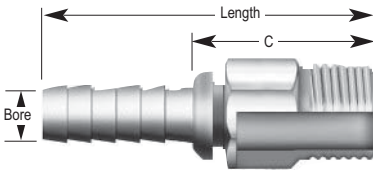

Thorburn Part #	Hose ID (in)	Thread Size	Bore Size (in)	Stem Hex (in)	Length (in)	"C" Cut-off (in)
4TC2-4MBSPT	1/4	1/4-19	.16	5/8	2.26	1.17
6TC2-6MBSPT	3/8	3/8-19	.27	3/4	2.20	1.18
8TC2-8MBSPT	1/2	1/2-14	.41	7/8	2.76	1.32
12TC2-12MBSPT	3/4	3/4-14	.63	1 1/8	3.21	1.50
16TC2-16MBSPT	1	1-11	.84	1 1/2	3.60	1.89

BSPB Swivel Female 45° Bent Tube

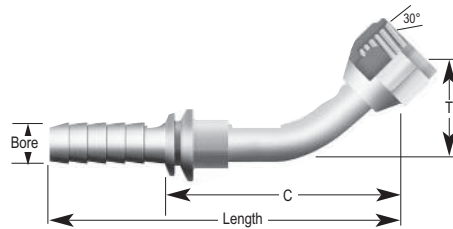

Thorburn Part #	Hose ID (in)	Thread Size	Nut Hex Size (in)	Stem Hex Size (in)	"T" Drop Dim. (in)	Coupling Length (in)	"C" Cut-off (in)
4TC2-4FBSPPX45	1/4	1/4-19	3/4	1/2	TBA	3.20	2.11
6TC2-6FBSPPX45	3/8	3/8-19	7/8	5/8	TBA	3.42	2.40
8TC2-8FBSPPX45	1/2	1/2-14	1	13/16	TBA	4.01	2.57
10TC2-10FBSPPX45	5/8	5/8-14	1 1/8	15/16	TBA	4.32	2.88
12TC2-12FBSPPX45	3/4	3/4-14	1 1/4	1 1/16	TBA	4.99	3.29
16TC2-16FBSPPX45	1	1-11	1 1/2	1 3/8	TBA	5.55	3.85
20TC2-20FBSPPX45	1 1/4	1 1/4-11	1 7/8	1 3/4	TBA	6.25	3.95

Komatsu & JIS Couplings

Female Komatsu Swivel

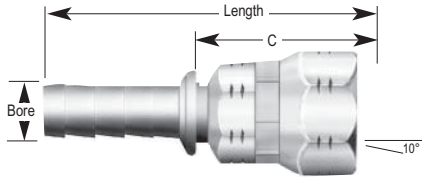

Thorburn Part #	Hose ID (in)	Thread Size	Bore Size (in)	Nut Hex (in)	Stem Hex (in)	Length (in)	"C" Cut-off (in)
4TC2-M14FKX	1/4	M14x1.5	.16	9/16	3/4	2.26	1.18
6TC2-M18FKX	3/8	M18x1.5	.27	11/16	7/8	2.35	1.33
8TC2-M22FKX	1/2	M22x1.5	.41	13/16	1 1/16	2.99	1.55
10TC2-M24FKX	5/8	M24x1.5	.50	1	1 1/4	3.13	1.69
12TC2-M30FKX	3/4	M30x1.5	.63	1 1/8	1 7/16	3.66	1.95
16TC2-M33FKX	1	M33x1.5	.84	1 3/8	1 5/8	4.01	2.30
20TC2-M36FKX	1 1/4	M36x1.5	1.06	1 3/4	2	5.05	2.75
24TC2-M42FKX	1 1/2	M42x1.5	1.31	2	2 3/8	5.49	2.86

Female Komatsu Swivel 45° Bent Tube

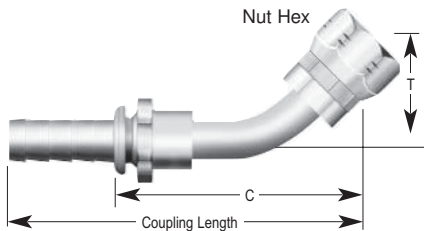

Thorburn Part #	Hose ID (in)	Thread Size	Nut Hex (in)	"T" Drop (in)	Length (in)	"C" Cut-off (in)
4TC2-M14FKX45	1/4	M14x1.5	3/4	.75	3.10	2.02
6TC2-M18FKX45	3/8	M18x1.5	7/8	.56	2.86	1.85
8TC2-M22FKX45	1/2	M22x1.5	1 1/16	.72	3.67	2.24
10TC2-M30FKX45	5/8	M30x1.5	1 1/4	1.11	4.46	3.02

Female Komatsu Swivel 90° Bent Tube

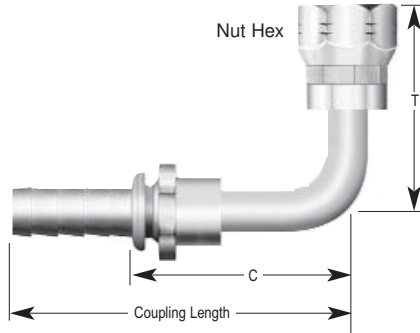

Thorburn Part #	Hose ID (in)	Thread Size	Nut Hex (in)	"T" Drop (in)	Length (in)	"C" Cut-off (in)
4TC2-M14FKX90	1/4	M14x1.5	3/4	1.50	2.75	2.02
6TC2-M18FKX90	3/8	M18x1.5	7/8	1.09	2.83	1.85
8TC2-M22FKX90	1/2	M22x1.5	1 1/16	1.38	3.37	2.24
10TC2-M24FKX90	5/8	M24x1.5	1 1/4	2.57	4.01	3.02

Japanese Series

JIS Female Swivel

(Japanese Industrial Standard)

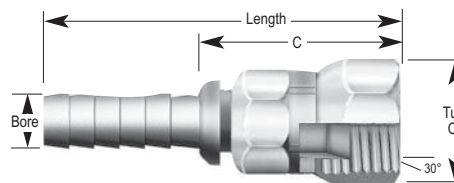

Thorburn Part #	Hose ID (in)	Thread Size	Bore Size (in)	Nut Hex (in)	Stem Hex (in)	Length (in)	"C" Cut-off (in)
4TC2-4FJISX	1/4	1/4-19	8	.16	.17	2.00	.91
6TC2-6FJISX	3/8	3/8-19	12	.27	.17	2.00	.99
8TC2-8FJISX	1/2	1/2-14	15	.41	.88	2.57	1.13
10TC2-12FJISX	5/8	5/8-14	18	.50	1.08	2.60	1.16
12TC2-12FJISX	3/4	3/4-14	22	.63	1.16	3.00	1.29
16TC2-16FJISX	1	1-11	28	.84	1.28	3.21	1.50

Japanese Series

JIS Female Swivel 45° Bent Tube

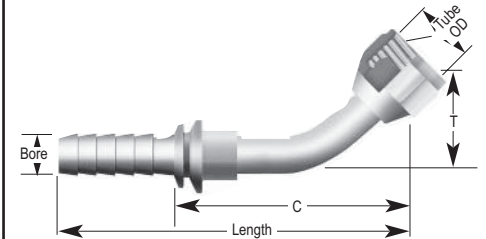

Thorburn Part #	Hose ID (in)	Thread Size	DIN Tube OD mm	Bore Size (in)	Stem Hex mm	Nut Hex mm	Length (in)	"C" Cut-off (in)
4TC2-M14FDLX45	1/4	M14x1.5	8	.16	17	.74	2.95	1.86
4TC2-M16FDLX45	1/4	M16x1.5	10	.16	19	.77	3.12	2.03
5TC2-M16FDLX45	5/16	M16x1.5	10	.23	19	.77	3.16	2.14
6TC2-M16FDLX45	3/8	M16x1.5	10	.27	19	.77	3.03	2.01
6TC2-M18FDLX45	3/8	M18x1.5	12	.27	22	1.02	3.53	2.51
6TC2-M22FDLX45	1/2	M22x1.5	15	.27	27	1.20	4.22	3.20
8TC2-M22FDLX45	1/2	M22x1.5	15	.41	27	1.20	4.70	3.26
10TC2-M26FDLX45	5/8	M26x1.5	18	.50	32	1.47	5.36	3.92
12TC2-M30FDLX45	3/4	M30x2.0	22	.63	36	1.34	5.41	3.70
16TC2-M36FDLX45	1	M36x2.0	28	.84	46	1.45	6.22	4.51
20TC2-M45FDLX45	1 1/4	M45x2.0	35	1.06	55	1.77	7.61	5.31

JIS Female Swivel 90° Bent Tube

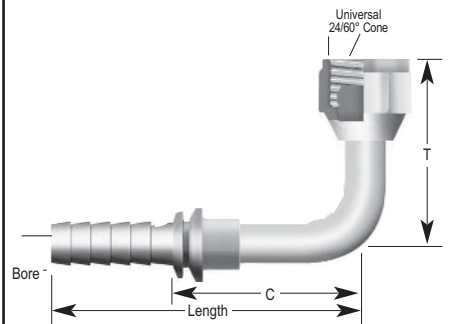

Thorburn Part #	Hose ID (in)	Thread Size	DIN Tube OD mm	Bore Size (in)	Nut Hex mm	"T" Drop (in)	"C" Length (in)	Cut-off (in)
3TC2-M12FDLX90	3/16	M12x1.5	6	.13	14	1.26	2.52	1.43
4TC2-M14FDLX90	1/4	M14x1.5	8	.16	17	1.26	2.43	1.36
4TC2-M16FDLX90	1/4	M16x1.5	10	.16	19	1.38	2.64	1.55
5TC2-M16FDLX90	5/16	M16x1.5	10	.23	19	1.38	2.68	1.66
6TC2-M16FDLX90	3/8	M16x1.5	10	.27	19	1.38	2.55	1.53
6TC2-M18FDLX90	3/8	M18x1.5	12	.27	22	1.77	2.84	1.82
8TC2-M22FDLX90	1/2	M22x1.5	15	.41	27	2.23	4.02	2.58
10TC2-M26FDLX90	5/8	M26x1.5	18	.50	32	2.64	4.55	3.11
12TC2-M30FDLX90	3/4	M30x2.0	22	.63	36	2.56	4.73	3.02
16TC2-M36FDLX90	1	M36x2.0	28	.84	46	2.79	5.50	3.79
20TC2-M45FDLX90	1 1/4	M45x2.0	35	1.06	55	3.50	6.83	4.53

Dimensions for reference only. Subject to change

DIN (Deutsche Industrial Norme) Couplings

DIN Male Light Series

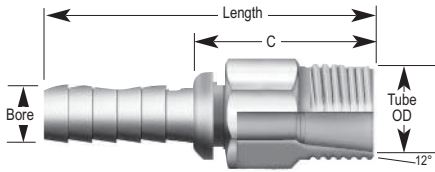

Thorburn Part #	Hose ID (in)	Thread Size	Nut Hex Size (mm)	Bore (in)	Stem Hex (in)	Length (in)	"C" Cut-off (in)
4TC2-14MDL	1/4	M14x1.5	8	.16	.17	2.00	.91
4TC2-16MDL	1/4	M16x1.5	10	.16	.17	2.06	.97
5TC2-16MDL	5/16	M16x1.5	10	.23	.17	2.00	.98
6TC2-16MDL	3/8	M16x1.5	10	.27	.17	2.00	.98
6TC2-18MDL	3/8	M18x1.5	12	.27	.17	2.00	.99
8TC2-22MDL	1/2	M22x1.5	15	.41	.88	2.57	1.13
10TC2-26MDL	5/8	M26x1.5	18	.50	1.08	2.60	1.16
12TC2-30MDL	3/4	M30x2.0	22	.63	1.16	3.00	1.29
16TC2-36MDL	1	M36x2.0	28	.84	1.28	3.21	1.50
20TC2-45MDL	1 1/4	M45x2.0	35	1.06	1.29	4.06	1.77

DIN Male Heavy Series

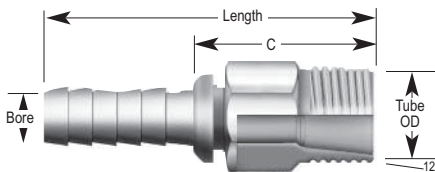

Thorburn Part #	Hose ID (in)	Thread Size	Bore Size (in)	Stem Hex (mm)	Length (in)	"C" Cut-off (in)
4TC2-16MDH	1/4	M16x1.5	.16	17	1.98	.89
4TC2-18MDH	1/4	M18x1.5	.16	19	2.02	.93
6TC2-18MDH	3/8	M18x1.5	.27	19	1.95	.93
6TC2-24MDH	3/8	M24x1.5	.27	22	1.95	.93
6TC2-22MDH	3/8	M22x1.5	.27	24	2.02	1.01
8TC2-20MDH	1/2	M20x1.5	.27	27	2.57	1.13
8TC2-24MDH	1/2	M24x1.5	.41	27	2.53	1.09
10TC2-30MDH	5/8	M30x2.0	.50	32	2.66	1.22
12TC2-36MDH	3/4	M36x2.0	.63	41	3.08	1.37

DIN Female Swivel Straight Light "O" Ring 24° Inverted Cone

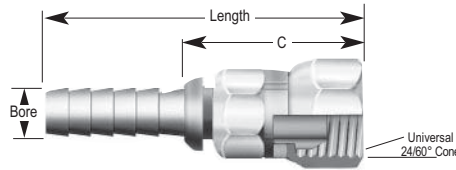

Thorburn Part #	Hose ID (in)	Thread Size	DIN Tube OD mm	Bore Size (in)	Stem Hex mm	Nut Hex mm	Length (in)	"C" Cut-off (in)
3TC2-12MFDLX	3/16	M12x1.5	6	.13	14	14	2.20	1.11
4TC2-12MFDLX	1/4	M12x1.5	6	.13	14	14	2.20	1.11
4TC2-14MFDLX	1/4	M14x1.5	8	.16	14	17	2.21	1.12
4TC2-16MFDLX	1/4	M16x1.5	10	.16	17	19	2.33	1.24
6TC2-16MFDLX	3/8	M16x1.5	10	.27	17	19	2.40	1.24
6TC2-18MFDLX	3/8	M18x1.5	12	.27	17	22	2.38	1.36
8TC2-22MFDLX	1/2	M22x1.5	15	.41	24	27	2.93	1.49
10TC2-26MFDLX	5/8	M26x1.5	18	.50	27	32	3.14	1.70
12TC2-30MFDLX	3/4	M30x1.5	22	.63	27	36	3.24	1.53
16TC2-36MFDLX	1	M36x2.0	28	.84	36	46	3.66	1.95
20TC2-45MFDLX	1 1/4	M45x2.0	35	1.06	46	55	4.76	2.46
24TC2-52MFDLX	1 1/2	M52x2.0	35	1.06	50	65	5.04	2.40

DIN Female Swivel Light "O" Ring 24° Cone Series 45° Bent Tube

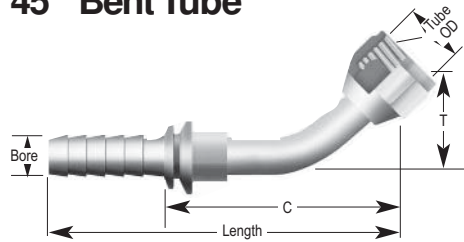

Thorburn Part #	Hose ID (in)	Thread Size	DIN Tube OD mm	Bore Size (in)	Stem Hex mm	Nut Hex mm	Length (in)	"C" Cut-off (in)
4TC2-14MFDLX45	1/4	M14x1.5	8	.16	17	.74	2.95	1.86
4TC2-16MFDLX45	1/4	M16x1.5	10	.16	19	.77	3.12	2.03
6TC2-16MFDLX45	3/8	M16x1.5	10	.27	19	.77	3.03	2.01
6TC2-18MFDLX45	3/8	M18x1.5	12	.27	22	1.02	3.53	2.51
6TC2-22MFDLX45	3/8	M22x1.5	15	.27	27	1.20	4.22	3.20
8TC2-22MFDLX45	1/2	M22x1.5	15	.41	27	1.20	4.70	3.26
10TC2-26MFDLX45	5/8	M26x1.5	18	.50	32	1.47	5.36	3.92
16TC2-36MFDLX45	1	M36x2.0	28	.84	46	1.45	6.22	4.51
20TC2-45MFDLX45	1 1/4	M45x2.0	35	1.06	55	1.77	7.61	5.31

DIN Female Swivel Light "O" Ring 24° Cone Series 90° Bent Tube

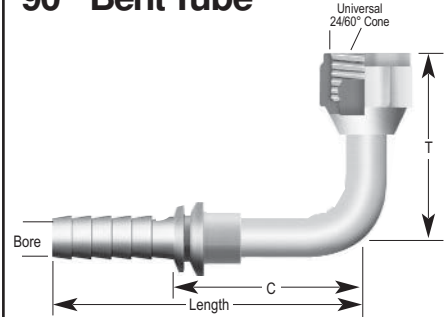

Thorburn Part #	Hose ID (in)	Thread Size	DIN Tube OD mm	Bore Size (in)	Nut Hex mm	"T" Drop (in)	"C" Length (in)	Cut-off (in)
4TC2-14MFDLX90	1/4	M14x1.5	8	.16	17	1.26	2.43	1.36
4TC2-16MFDLX90	1/4	M16x1.5	10	.16	19	1.38	2.64	1.55
6TC2-16MFDLX90	3/8	M16x1.5	10	.27	19	1.38	2.55	1.53
6TC2-18MFDLX90	3/8	M18x1.5	12	.27	22	1.77	2.84	1.82
8TC2-22MFDLX90	1/2	M22x1.5	15	.41	27	2.23	4.02	2.58
10TC2-26MFDLX90	5/8	M26x1.5	18	.50	32	2.64	4.55	3.11
12TC2-30MFDLX90	3/4	M30x2.0	22	.63	36	2.56	4.73	3.02
16TC2-36MFDLX90	1	M36x2.0	28	.84	46	2.79	5.50	3.79
20TC2-45MFDLX90	1 1/4	M45x2.0	35	1.06	55	3.50	6.83	4.53

DIN Female Swivel Straight Heavy Series 24° Inverted Cone with "O" Ring

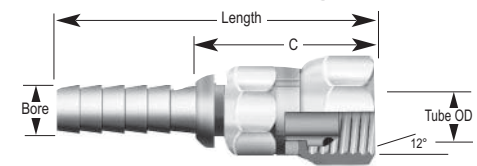

Thorburn Part #	Hose ID (in)	Thread Size	DIN Tube OD mm	Bore Size (in)	Stem Hex mm	Nut Hex mm	Length (in)	"C" Cut-off (in)
4TC2-16MFDHX	1/4	M16x1.5	8	.16	14	19	2.34	1.25
4TC2-18MFDHX	1/4	M18x1.5	10	.16	22	22	2.42	1.34
5TC2-20MFDHX	5/16	M20x1.5	12	.23	19	24	2.37	1.35
6TC2-22MFDHX	3/8	M22x1.5	14	.41	27	27	2.51	1.49
8TC2-22MFDHX	1/2	M22x1.5	14	.27	24	27	3.07	1.63
8TC2-24MFDHX	1/2	M24x1.5	16	.41	24	30	3.01	1.57
10TC2-30MFDHX	5/8	M30x1.5	20	.50	27	36	3.27	1.84
10TC2-36MFDHX	5/8	M36x2.0	25	.50	36	46	3.52	2.08
12TC2-30MFDHX	3/4	M30x2.0	20	.63	27	36	3.55	1.84
12TC2-36MFDHX	3/4	M36x2.0	25	.63	36	46	3.79	2.08
16TC2-42MFDHX	1	M42x2.0	30	.84	46	51	4.19	2.48

DIN Female Swivel Heavy 24° Cone Series 45° Bent Tube

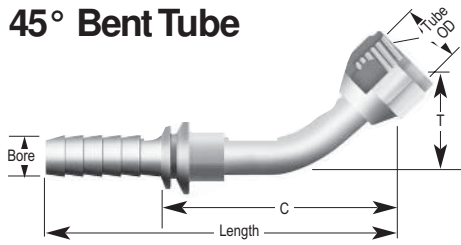

Thorburn Part #	Hose ID (in)	Thread Size	DIN Tube OD mm	Bore Size (in)	Stem Hex mm	Nut Hex mm	Length (in)	"C" Cut-off (in)
6TC2-20MFDHX45	3/8	M20x1.5	12	.27	24	.63	3.03	2.01
8TC2-24MFDHX45	1/2	M24x1.5	16	.41	30	.86	4.21	2.77
10TC2-30MFDHX45	5/8	M30x2.0	20	.50	36	.98	4.65	3.21
12TC2-36MFDHX45	3/4	M36x2.0	25	.63	46	1.15	5.27	3.56

DIN Female Swivel Heavy Series 90° Bent Tube

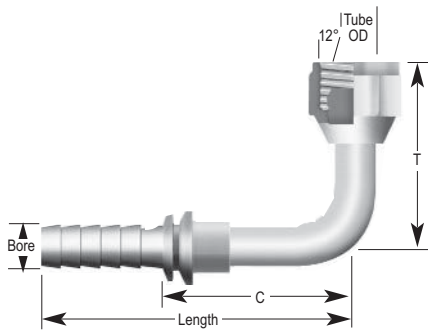

Thorburn Part #	Hose ID (in)	Thread Size	DIN Tube OD mm	Bore Size (in)	Nut Hex mm	"T" Drop (in)	Length (in)	"C" Cut-off (in)
4TC2-18MFDHX90	1/4	M18x1.5	10	.24	22	1.69	2.73	1.65
6TC2-18MFDHX90	3/8	M18x1.5	10	.24	22	1.69	2.64	1.63
6TC2-22MFDHX90	3/8	M22x1.5	14	.27	27	1.44	2.78	1.76
8TC2-24MFDHX90	1/2	M24x1.5	16	.41	30	1.80	3.95	2.51
10TC2-30MFDHX90	5/8	M30x2.0	20	.50	36	2.22	4.08	2.64
12TC2-36MFDHX90	3/4	M36x2.0	25	.50	46	2.10	4.85	3.14

Metric Stand Pipe Light/Heavy Series

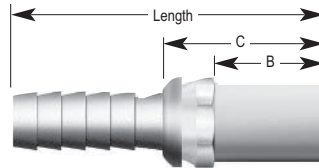

Thorburn Part #	Hose ID (in)	DIN Tube OD (mm)	Stem Hex (mm)	Length (in)	"C" Cut-off (in)	"B" Tube Length
4TC2-6MLHP	1/4	6	13	3.59	1.50	.87
4TC2-8MLHP	1/4	8	13	2.58	1.49	.87
6TC2-10MLHP	3/8	10	16	2.55	1.55	.91
8TC2-15MLHP	1/2	15	21	3.09	1.65	.98
12TC2-22MLHP	3/4	22	27	3.53	1.82	1.10
16TC2-28MLHP	1	28	35	3.73	2.02	1.18

Metric Bite Sleeve Light/Heavy Series



Thorburn Part #	DIN Tube OD (mm)
6TC2BLH	6
8TC2BLH	8
10TC2BLH	10
12TC2BLH	12
14TC2BLH	14
15TC2BLH	15
16TC2BLH	16
18TC2BLH	18
20TC2BLH	20
22TC2BLH	22
25TC2BLH	25
28TC2BLH	28
30TC2BLH	30
35TC2BLH	35
38TC2BLH	38
42TC2BLH	42

Metric Bite Nut Light/Heavy Series

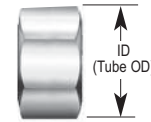

Thorburn Part #	Thread Size	DIN Tube OD (mm)
6TC2-12MNL	M12x1.5	6
6TC2-14MNH	M14x1.5	6
8TC2-14MNL	M14x1.5	8
8TC2-16MNH	M16x1.5	8
10TC2-16MNL	M16x1.5	10
10TC2-18MNH	M18x1.5	10
12TC2-18MNL	M18x1.5	12
12TC2-20MNH	M20x1.5	12
14TC2-22MNH	M22x1.5	14
15TC2-22MNL	M22x1.5	15
16TC2-24MNH	M24x1.5	16
18TC2-26MNL	M26x1.5	18
20TC2-30MNH	M30x2.0	20
22TC2-30MNL	M30x2.0	22
25TC2-36MNH	M36x2.0	25
28TC2-36MNL	M36x2.0	28
30TC2-42MNH	M42x2.0	30
35TC2-45MNL	M45x2.0	35
38TC2-52MNH	M52x2.0	38
42TC2-52MNL	M52x2.0	42

Thor-Crimp Series IV Stainless Steel Spiral Stems & Ferrules for TR12 Hose

Series IV Ferrules

Thor-Crimp Spirals Series IV IIIA / B
Ferrules for use with TR12 & Hoses

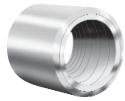

Material:
SS316

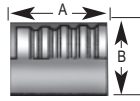

Non-Skive for TR12

Skive for TR12

Thorburn Part #	Hose ID (in)	A	B	Thorburn Part #	Hose ID (in)	A	B
491F06S6	3/8	1.10	1.23	492F06S6	3/8	1.10	1.01
491F08S6	1/2	1.50	1.35	492F08S6	1/2	1.50	1.21
491F012S6	3/4	1.97	1.65	492F012S6	3/4	1.97	1.36
491F06S6	1	2.20	1.98	492F06S6	1	2.07	1.87
491F020S6	1 1/4	2.77	2.43	492F020S6	1 1/4	2.77	2.25
491F024S6	1 1/2	3.50	2.77	492F024S6	1 1/2	2.77	2.54
491F032S6	2	3.43	3.34	492F032S6	2	3.43	3.08

NPTF Solid Male

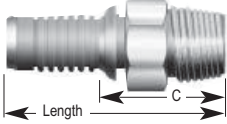

Material: SS316

Thorburn Part #	Hose ID (in)	Thread Size	Hex Size (in)	Bore Size (in)	Coupling Length (in)	"C" Cut-off (in)
490MP-6-6S6	3/8	3/8-18	1 1/16	.265	2.25	1.22
490MP-8-8S6	1/2	1/2-14	7/8	.406	2.90	1.42
490MP-12-12S6	3/4	3/4-14	1 1/16	.594	3.55	1.54
490MP-16-16S6	1	1-11 1/2	1 3/8	.828	4.16	1.92
490MP-20-20S6	1 1/4	1 1/4-11 1/2	1 3/4	1.062	4.98	2.18
490MP-24-24S6	1 1/2	1 1/2-11 1/2	2	1.19	5.14	2.34
490MP-32-32S6	2	2-11 1/2	2 1/2	1.750	5.88	2.33

One piece coupling only.

O-Ring Boss Solid Male

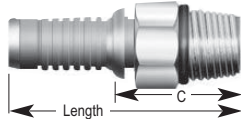

Material: SS316

Thorburn Part #	Hose ID (in)	Thread Size	Hex Size (in)	Bore Size (in)	Coupling Length (in)	"C" Cut-off (in)
490MB-6-6S6	3/8	3/8-18	1 1/16	.265	2.19	1.16
490MB-8-8S6	1/2	3/4-16	7/8	.406	2.59	1.11
490MB-12-12S6	3/4	1 1/16-12	1 1/4	.594	3.46	1.45
490MB-16-16S6	1	1 5/16-12	1 1/2	.828	3.78	1.54
490MB-20-20S6	1 1/4	1 5/8-12	1 7/8	1.062	4.37	1.57

Female Flat-Face "O" Seal Swivel Straight

Material: SS316

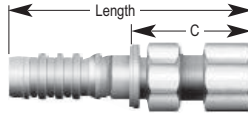

Thorburn Part #	Hose ID (in)	Thread Size	Hex A Size (in)	Hex B Size (in)	Bore Size (in)	Coupling Lgth (in)	"C" Cut-off (in)
490FFX-6-6S6	3/8	1 1/16-16	1 3/16	5/8	.265	2.32	1.29
490FFX-8-8S6	1/2	1 3/16-16	1 5/8	1 1/16	.406	2.88	1.41
490FFX-12-12S6	3/4	1 3/8-12	1 3/8	1 1/16	.594	3.91	1.90
490FFX-16-16S6	1	1 7/8-12	1 5/8	1 3/8	.828	4.42	2.13
490FFX-20-20S6	1 1/4	1 11/16-12	1 7/8	1 3/4	1.062	5.17	2.37
490FFX-24-24S6	1 1/2	2-12	2	2 1/4	1.25	5.17	2.32

Female Flat-Face "O" Seal Swivel 45°

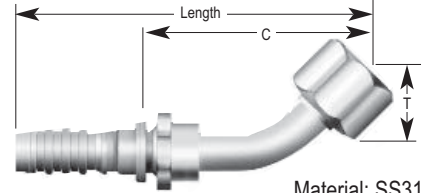

Material: SS316

Thorburn Part #	Hose ID (in)	Thread Size	Hex A Size (in)	Hex B Size (in)	Bore Size (in)	Coupling Lgth (in)	"C" Cut-off (in)	"T" Drop Dim.
490FFX45-6-6S6	3/8	1 1/16-16	1 3/16	3/4	.265	2.81	1.79	.43
490FFX45-8-8S6	1/2	1 3/16-16	1 5/8	3/4	.406	4.05	2.58	.59
490FFX45-12-12S6	3/4	1 3/8-12	1 3/8	1 1/16	.594	4.93	2.92	.83
490FFX45-16-16S6	1	1 7/8-12	1 5/8	1 3/8	.828	5.79	3.55	.94
490FFX45-20-20S6	1 1/4	1 11/16-12	1 7/8	1 3/4	1.062	6.92	4.12	1.00
490FFX45-24-24S6	1 1/2	2-12	2	2 1/4	1.28	7.54	4.74	1.07

Female Flat-Face "O" Seal Swivel 90°

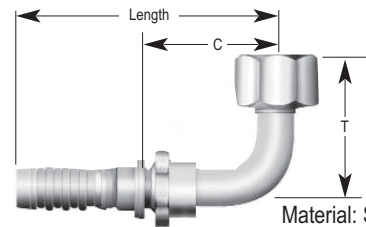

Material: SS316

Thorburn Part #	Hose ID (in)	Thread Size	Hex A Size (in)	Hex B Size (in)	Bore Size (in)	Coupling Lgth (in)	"C" Cut-off (in)	"T" Drop Dim.
490FFX90-6-6S6	3/8	1 1/16-16	1 3/16	3/4	.265	2.68	1.60	.90
490FFX90-8-8S6	1/2	1 3/16-16	1 5/8	3/4	.406	3.46	1.88	1.15
490FFX90-12-12S6	3/4	1 3/8-12	1 3/8	1 1/16	.594	4.82	2.81	2.28
490FFX90-16-16S6	1	1 7/8-12	1 5/8	1 3/8	.828	5.72	3.49	2.78
490FFX90-20-20S6	1 1/4	1 11/16-12	1 7/8	1 3/4	1.062	6.90	4.11	3.09
490FFX90-24-24S6	1 1/2	2-12	2	2 1/4	1.281	7.61	4.81	3.41

Other sizes available upon request.

Thor-Crimp Series IV Stainless Steel Spiral Stems & Ferrules for TR12 Hose

Male JIC (37° Flare)

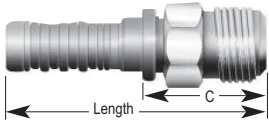

Material: SS316

Thorburn Part #	Hose ID (in)	Thread Size	Hex Size (in)	Bore Size (in)	Coupling Length (in)	"C" Cut-off (in)
490MJ-6-6S6	3/8	9/16-18	11/16	.265	2.19	1.16
490MJ-8-8S6	1/2	3/4-16	13/16	.406	2.81	1.33
490MJ-12-12S6	3/4	1 1/16-12	1 1/8	.594	3.66	1.66
490MJ-16-16S6	1	1 1/8-12	1 3/8	.828	4.10	1.86
490MJ-20-20S6	1 1/4	1 5/8-12	1 3/4	.828	4.91	2.11
490MJ-24-24S6	1 1/2	1 7/8-12	2	1.281	5.04	2.24
490MJ-32-32S6	2	2 1/2-12	2 5/8	1.750	6.14	1.59

Other sizes available upon request.

Female 37° Flare (JIC) Swivel

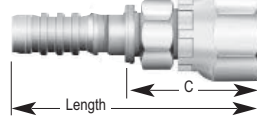

Material: SS316

Thorburn Part #	Hose ID (in)	Thread Size	Nut Hex (in)	Stem Hex (in)	Bore Size (in)	Coupling Length (in)	"C" Cut-off (in)
490FJX-6-6S6	3/8	9/16-18	.750	.68	.265	2.27	1.25
490FJX-8-8S6	1/2	3/4-16	.875	.812	.406	2.80	1.33
490FJX-12-12S6	3/4	1 1/16-12	1.25	1.06	.594	3.769	1.76
490FJX-16-16S6	1	1 1/8-12	1	1.37	.828	4.134	1.90
490FJX-20-20S6	1 1/4	1 5/8-12	2	1.75	1.062	5.290	2.49
490FJX-24-24S6	1 1/2	1 7/8-12	2.37	2	1.281	5.420	2.62
490FJX-32-32S6	2	2 1/2-12	3	2.5	1.750	6.580	3.03

JIC Swivel Female 45° Bent Tube

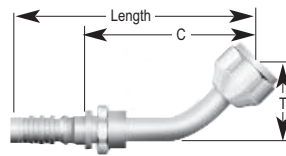

Material: SS316

Thorburn Part #	Hose ID (in)	Thread Size	Hex Size (in)	"T" Drop Dim (in)	Coupling Length (in)	"C" Cut-off (in)
490JX45-6-6S6	3/8	9/16-18	.87	.98	3.36	2.34
490FJX45-8-8S6	1/2	3/4-16	.87	.69	3.78	2.31
49012FJX45-12-12S6	3/4	1 1/16-12	1.5	1.50	5.30	3.29
490FJX45-16-16S6	1	1 1/8-12	1.5	1.50	5.68	3.44
490FJX45-20-20S6	1 1/4	1 5/8-12	2	1.60	8.15	5.35
490FJX45M-24-24S6	1 1/2	1 7/8-12	2.38	2.00	9.02	6.22

Other sizes available upon request.

JIC Swivel Female 90° Bent Tube

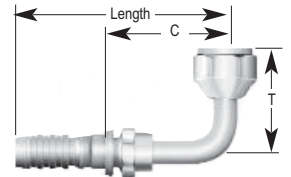

Material: SS316

Thorburn Part #	Hose ID (in)	Thread Size	Hex Size (in)	"T" Drop Dim (in)	Coupling Length (in)	"C" Cut-off (in)
490FJX90-6-6S6	3/8	9/16-18	.75	.85	2.67	1.65
490FJX90-8-8S6	1/2	3/4-16	.81	1.71	3.46	1.98
490FJX90M-12-12S6	3/4	1 1/16-12	1.25	2.49	4.39	2.38
490FJX90M-16-16S6	1	1 1/8-12	1.50	3.14	5.21	2.97
490FJX90M-20-20S6	1 1/4	1 5/8-12	2.00	5.00	6.16	3.36

Other sizes available upon request.

Thor-Crimp Series IV Stainless Steel Spiral (TCS) Stems for TR12 Hoses

“O” Seal Flange Straight (Code 61-SAE J518)

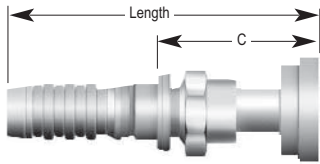

Thorburn Part #	Hose ID (in)	Nom. Fig. Dia. (in)	“M” Fig. Dia. (in)	Coupling Length (in)	“C” Cut-off (in)
490FL-8-8S6	1/2	1/2	1.19	3.63	1.92
490FL-12-12S6	3/4	3/4	1.50	4.37	2.36
490FL-16-16S6	1	1	1.75	4.48	2.24
490FL-20-20S6	1 1/4	1 1/4	2.00	5.71	2.91
490FL-24-24S6	1 1/2	1 1/2	2.38	5.79	2.99
490FL-32-32S6	2	2	2.81	6.08	2.54

Other sizes available upon request.

“O” Seal Flange 45° Bent Tube (Code 61-SAE J518)

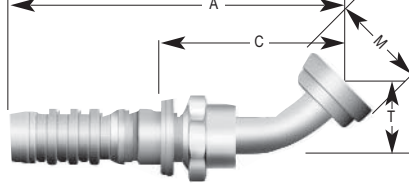

Thorburn Part #	Hose ID (in)	Nom. Fig. Dia. (in)	“M” Fig. Dia. (in)	“T” Drop Dim. (in)	Coupling Length (in)	“C” Cut-off (in)
490FL45-8-8S6	1/2	1/2	1.19	.78	3.58	2.11
490FL45-12-12S6	3/4	3/4	1.50	1.00	4.67	2.67
490FL45-16-16S6	1	1	1.75	1.12	5.31	3.07
490FL45-20-20S6	1 1/4	1 1/4	2.00	1.27	6.41	3.61
490FL45-24-24S6	1 1/2	1 1/2	2.38	1.44	7.03	4.23
490FL45-32-32S6	2	2	2.81	2.00	8.52	4.98

Other sizes available upon request.

“O” Seal Flange 90° Bent Tube (Code 61-SAE J518)

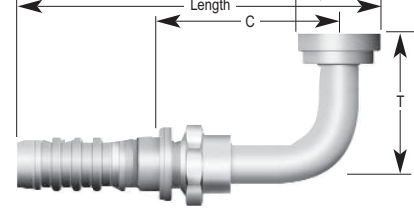

Thorburn Part #	Hose ID (in)	Nom. Fig. Dia. (in)	“M” Fig. Dia. (in)	“T” Drop Dim. (in)	“A” Dim. (in)	“C” Cut-off (in)
490FL90-8-8S6	1/2	1/2	1.19	1.60	3.46	1.99
490FL90-12-12S6	3/4	3/4	1.50	3.93	4.39	2.38
490FL90-16-16S6	1	1	1.75	2.60	5.21	2.97
490FL90-20-20S6	1 1/4	1 1/4	2.00	2.81	6.16	3.36
490FL90-24-24S6	1 1/2	1 1/2	2.38	3.12	6.67	3.88
490FL90-32-32S6	2	2	2.81	4.50	8.52	4.98

Other sizes available upon request.

Carbon Steel Ferrules & Stems for TR12 Hose

Series IV Ferrules

Thor-Crimp Spirals Series (TCS) IV A / B
 Ferrules for use with TR12 Hoses



Skive for TR12

Thorburn Part #	Hose ID (in)	A	B
6TC4SF	3/8	1.10	1.01
8TC4SF	1/2	1.50	1.21
12TC4SF	3/4	1.97	1.36
16TC4SF	1	2.07	1.87
20TC4SF	1 1/4	2.77	2.25
24TC4SF	1 1/2	2.77	2.54
32TC4SF	2	3.43	3.08

O-Ring Boss Solid Male

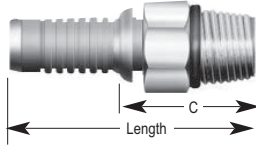

Thorburn Part #	Hose ID (in)	Thread Size	Hex Size (in)	Bore Size (in)	Coupling Length (in)	"C" Cut-off (in)
6TC4-6MB	3/8	3/16-18	11/16	.265	2.19	1.16
8TC4-8MB	1/2	3/4-16	7/8	.406	2.59	1.11
8TC4-10MB	1/2	7/8-14	1	.406	2.82	1.35
12TC4-12MB	3/4	1 1/16-12	1 1/4	.594	3.46	1.45
12TC4-16MB	3/4	1 5/16-12	1 1/2	.594	3.45	1.44
16TC4-16MB	1	1 5/8-12	1 1/2	.828	3.78	1.54
20TC4-20MB	1 1/4	1 5/8-12	1 7/8	1.062	4.37	1.57

NPTF Solid Male

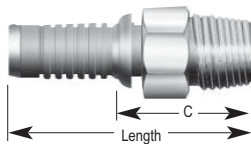

Thorburn Part #	Hose ID (in)	Thread Size	Hex Size (in)	Bore Size (in)	Coupling Length (in)	"C" Cut-off (in)
6TC4-6MP	3/8	3/8-18	11/16	.265	2.25	1.22
6TC4-8MP	3/8	1/2-14	7/8	.265	2.44	1.41
8TC4-8MP	1/2	1/2-14	7/8	.406	2.90	1.42
8TC4-12MP	1/2	3/4-14	1 1/16	.406	3.02	1.55
12TC4-12MP	3/4	3/4-14	1 1/16	.594	3.55	1.54
12TC4-16MP	3/4	1-11 1/2	1 3/8	.594	3.83	1.82
16TC4-12MP	1	3/4-14	1 1/16	.830	3.97	1.73
16TC4-16MP	1	1-11 1/2	1 3/8	.828	4.16	1.92
16TC4-16MP LH**	1	1-11 1/2	1 3/8	.828	5.16	2.92
16TC4-20MP	1	1 1/4-11 1/2	1 3/4	.828	4.34	2.10
20TC4-20MP	1 1/4	1 1/4-11 1/2	1 3/4	1.062	4.98	2.18
24TC4-24MP	1 1/2	1 1/2-11 1/2	2	1.281	5.14	2.34
32TC4-32MP	2	2-11 1/2	2 1/2	1.750	5.88	2.33
32TC4-32MP API	2	2-11 1/2	2 1/2	1.750	7.72	4.18

**LH=Long Hex

Male JIC (37° Flare)

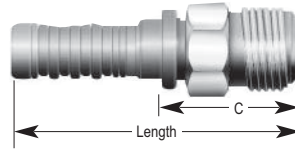

Thorburn Part #	Hose ID (in)	Thread Size	Hex Size (in)	Bore Size (in)	Coupling Length (in)	"C" Cut-off (in)
6TC4-6MJ	3/8	3/16-18	11/16	.265	2.19	1.16
8TC4-8MJ	1/2	3/4-16	13/16	.406	2.81	1.33
8TC4-10MJ	1/2	7/8-14	7/8	.406	2.92	1.45
12TC4-12MJ	3/4	1 1/16-12	1 1/8	.594	3.66	1.66
12TC4-14MJ	3/4	1 3/16-12	1 1/4	.594	3.69	1.68
12TC4-16MJ	3/4	1 5/16-12	1 5/16	.594	3.77	1.76
16TC4-16MJ	1	1 5/8-12	1 3/8	.828	4.10	1.86
16TC4-20MJ	1	1 5/8-12	1 3/4	.844	4.27	2.04
20TC4-16MJ	1 1/4	1 5/8-12		.844	4.86	2.06
20TC4-20MJ	1 1/4	1 5/8-12	1 3/4	1.062	4.91	2.11
24TC4-20MJ	1 1/2	1 5/8-12	2	1.281	4.92	2.12
24TC4-24MJ	1 1/2	1 7/8-12	2	1.19	5.04	2.24
32TC4-24MJ	2	1 7/8-12	2	1.281	5.93	2.38
32TC4-32MJ	2	2 1/2-12	2 5/8	1.750	6.14	1.59

Female 37° Flare (JIC) Swivel

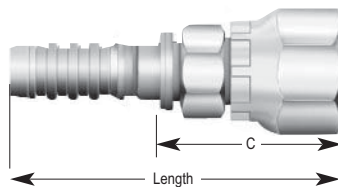

Thorburn Part #	Hose ID (in)	Thread Size	Nut Hex (in)	Stem Hex (in)	Bore Size (in)	Coupling Length (in)	"C" Cut-off (in)
6TC4-6FJX	3/8	3/16-18	.750	.68	.265	2.27	1.25
6TC4-8FJX	3/8	3/4-16	.875	.68	.265	2.36	1.34
8TC4-8FJX	1/2	3/4-16	.875	.812	.406	2.80	1.33
8TC4-10FJX	1/2	7/8-14	1.06	.875	.406	3.15	1.54
12TC4-12FJX	3/4	7/8-14	1.06	.875	.406	3.15	1.54
12TC4-10FJX	3/4	7/8-14	1.25	.812	.410	2.99	1.51
12TC4-12FJX	3/4	1 1/16-12	1.25	1.06	.594	3.769	1.76
12TC4-14FJX	3/4	1 3/16-12	1.37	1.12	.594	3.82	1.81
12TC4-16FJX	3/4	1 5/16-12	1.5	1.25	.594	3.778	1.77
16TC4-12FJX	1	1 1/16-12	1.25	1.37	.828	4.13	1.90
16TC4-16FJX	1	1 5/16-12	1	1.37	.828	4.134	1.90
16TC4-20FJX	1	1 5/8-12	2	1.37	.844	4.69	2.45
20TC4-16FJX	1 1/4	1 5/8-12	1.75	1.50	1.06	5.42	2.16
20TC4-20FJX	1 1/4	1 5/8-12	2	1.75	1.062	5.29	2.49
24TC4-24FJX	1 1/2	1 7/8-12	2.37	2	1.281	5.42	2.62
24TC4-32FJX	1 1/2	2 1/2-12	3	2.5	1.28	5.87	3.07
32TC4-32FJX	2	2 1/2-12	3	2.5	1.75	6.58	3.03

JIC Swivel Female 45° Bent Tube

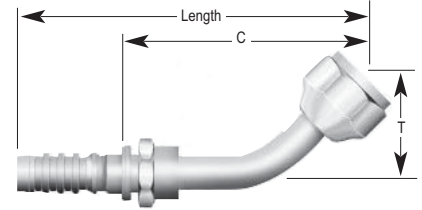

Thorburn Part #	Hose ID (in)	Thread Size	Hex Size (in)	"T" Drop Dim (in)	Coupling Length (in)	"C" Cut-off (in)
6TC4-6FJX45S	3/8	3/16-18	.75	.39	2.72	1.70
6TC4-6FJX45M	3/8	3/16-18	.87	.98	3.36	2.34
6TC4-8FJX45L	3/8	3/4-16	.87	1.08	3.76	2.73
8TC4-8FJX45S	1/2	3/4-16	.87	.55	3.64	2.16
8TC4-8FJX45M	1/2	3/4-16	.87	.69	3.78	2.31
8TC4-8FJX45L	1/2	3/4-16	.87	1.14	4.23	6.22
8TC4-10FJX45S	1/2	7/8-14	1.06	.63	3.54	2.06
12TC4-12FJX45	3/4	1 1/16-12	1.25	1.25	4.93	2.92
12TC4-16FJX45	3/4	1 5/16-12	1.5	1.50	5.30	3.29
16TC4-16FJX45	1	1 5/16-12	1.5	1.50	5.68	3.44
16TC4-20FJX45M	1	1 5/8-12	1.5	1.50	6.62	4.38
20TC4-20FJX45M	1 1/4	1 5/8-12	2	1.60	8.15	5.35
24TC4-24FJX45M	1 1/2	1 7/8-12	2.38	2.00	9.02	6.22

JIC Swivel Female 90° Bent Tube

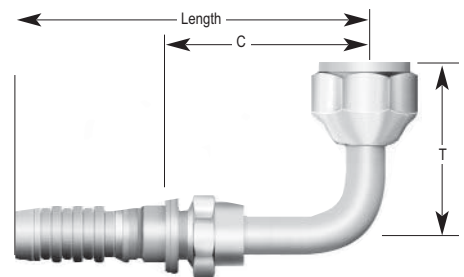

Thorburn Part #	Hose ID (in)	Thread Size	Hex Size (in)	"T" Drop Dim (in)	Coupling Length (in)	"C" Cut-off (in)
6TC4-6FJX90	3/8	3/16-18	.75	.85	2.67	1.65
8TC4-8FJX90S	1/2	3/4-16	.81	1.09	3.36	1.88
8TC4-8FJX90M	1/2	3/4-16	.81	1.71	3.46	1.98
8TC4-8FJX90L	1/2	3/4-16	.81	2.43	3.61	2.13
8TC4-10FJX90S	1/2	7/8-14	.81	1.71	3.46	1.98
8TC4-12FJX90S	1/2	1 1/16-12	1.25	1.82	4.36	2.88
12TC4-12FJX90S	3/4	1 1/16-12	1.25	1.82	4.39	2.38
12TC4-12FJX90M	3/4	1 1/16-12	1.25	2.49	4.39	2.38
12TC4-12FJX90L	3/4	1 1/16-12	1.25	3.73	4.77	2.76
12TC4-14FJX90M	3/4	1 3/16-12	1.37	2.38	5.39	3.39
12TC4-16FJX90M	3/4	1 5/16-12	1.50	3.14	5.56	3.55
16TC4-16FJX90S	1	1 5/16-12	1.50	2.14	5.50	3.26
16TC4-16FJX90M	1	1 5/16-12	1.50	3.14	5.21	2.97
16TC4-16FJX90L	1	1 5/16-12	1.50	4.33	5.50	3.26
16TC4-20FJX90M	1	1 5/8-12	2.00	5.00	5.21	2.97
20TC4-20FJX90S	1 1/4	1 5/8-12	2.00	3.00	6.16	3.36
20TC4-20FJX90M	1 1/4	1 5/8-12	2.00	5.00	6.16	3.36

Dimensions for reference only. Subject to change

“O” Seal Flange Straight (Code 62-SAE J518)

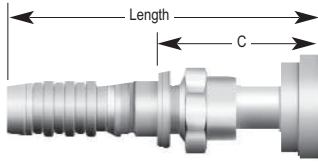

Thorburn Part #	Hose ID (in)	Nom. Fig. Dia. (in)	“M” Fig. Dia. (in)	Coupling Length (in)	“C” Cut-off (in)
8TC4-8FH	1/2	1/2	1.19	3.63	1.92
12TC4-12FLH	3/4	3/4	1.63	4.50	2.49
12TC4-16FLH	3/4	1	1.88	4.73	2.49
16TC4-16FLH	1	1	1.88	4.73	2.49
16TC4-20FHL	1	1 1/4	2.13	4.92	2.68
20TC4-20FLH	1 1/4	1 1/4	2.13	6.15	3.35
20TC4-24FLH	1 1/4	1 1/2	2.50	6.28	3.48
24TC4-24FH	1 1/2	1 1/2	2.50	6.36	3.56
24TC4-32FLH	1 1/2	2	3.13	6.67	3.87
32TC4-32FLH	2	2	3.13	6.96	3.42
* 24TC4-24FLFF	1 1/2	1 1/2	2.50	6.96	3.56

* Flat face.

“O” Seal Flange 45° Bent Tube (Code 62-SAE J518)

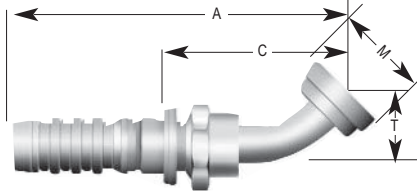

Thorburn Part #	Hose ID (in)	Nom. Fig. Dia. (in)	“M” Fig. Dia. (in)	“T” Drop Dim. (in)	Coupling Length (in)	“C” Cut-off (in)
8TC4-8FLH45	1/2	1/2	1.19	.78	3.58	2.11
8TC4-12FLH45	1/2	3/4	1.63	1.09	3.89	2.41
12TC4-12FLH45	3/4	3/4	1.63	1.09	4.76	2.76
12TC4-16FLH45	3/4	1	1.88	1.18	4.85	2.85
16TC4-16FLH45	1	1	1.88	1.29	5.48	3.24
16TC4-20FLH45	1	1 1/4	2.13	1.43	5.62	3.38
20TC4-20FLH45	1 1/4	1 1/4	2.13	1.58	6.72	3.92
20TC4-24FLH45	1 1/4	1 1/2	2.50	1.67	6.81	4.01
24TC4-24FLH45	1 1/2	1 1/2	2.50	1.84	7.43	4.63
24TC4-32FLH45	1 1/2	2	3.13	2.06	7.65	4.85
32TC4-32FLH45	2	2	3.13	2.62	9.14	5.60
16TC4-16FLH60	1	1	1.88	1.50	5.90	3.66

“O” Seal Flange 90° Bent Tube (Code 62-SAE J518)

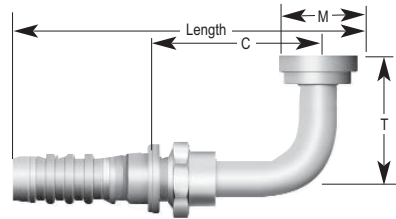

Thorburn Part #	Hose ID (in)	Nom. Fig. Dia. (in)	“M” Fig. Dia. (in)	“T” Drop Dim. (in)	“A” Dim. (in)	“C” Cut-off (in)
8TC4-8FLH90	1/2	1/2	1.19	1.63	3.46	1.99
8TC4-12FLH90	1/2	3/4	1.63	2.26	3.46	1.99
12TC4-12FLH90	3/4	3/4	1.63	2.26	4.39	2.38
12TC4-16FLH90	3/4	1	1.88	2.38	4.39	2.38
16TC4-16FLH90	1	1	1.88	2.85	5.21	2.97
16TC4-20FLH90	1	1 1/4	2.13	3.04	5.21	2.97
20TC4-20FLH90	1 1/4	1 1/4	2.13	3.25	6.16	3.36
20TC4-24FLH90	1 1/4	1 1/2	2.50	3.38	6.16	3.36
24TC4-24FLH90	1 1/2	1 1/2	2.50	3.69	6.67	3.88
24TC4-32FLH90	1 1/2	2	3.13	4.00	6.67	3.88
32TC4-32FLH90	2	2	3.13	5.38	8.52	4.98

Male Flat-Face “O” Seal

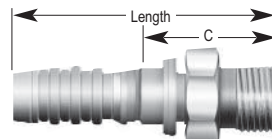

Thorburn Part #	Hose ID (in)	Thread Size	Hex Size (in)	Bore Size (in)	Coupling Lgth (in)	“C” Cut-off (in)
6TC4-6MFF	3/8	1 1/16-16	3/4	.265	2.01	.98
8TC4-8MFF	1/2	1 3/16-16	7/8	.406	2.58	1.10
12TC4-12MFF	3/4	1 3/16-12	1 1/4	.594	3.33	1.32
16TC4-16MFF	1	1 7/16-12	1 1/2	.828	3.67	1.43
20TC4-20MFF	1 1/4	1 11/16-12	1 3/4	1.062	4.31	1.51

Female Flat-Face “O” Seal Swivel Straight

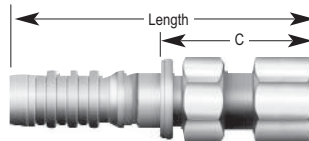

Thorburn Part #	Hose ID (in)	Thread Size	Hex A Size (in)	Hex B Size (in)	Bore Size (in)	Coupling Lgth (in)	“C” Cut-off (in)
6TC4-6FFX	3/8	1 1/16-16	1 3/16	5/8	.265	2.32	1.29
6TC4-8FFX	3/8	1 3/16-16	1 5/16	3/4	.265	2.46	1.44
8TC4-8FFX	1/2	1 3/16-16	1 5/16	3/4	.406	2.88	1.41
8TC4-10FFX	1/2	1-14	1 9/16	1 3/8	.406	3.07	1.59
12TC4-10FFX	3/4	1-14	1 1/8	1 1/8	.594	3.80	1.79
12TC4-12FFX	3/4	1 3/16-12	1 3/8	1 1/8	.594	3.91	1.90
12TC4-16FFX	3/4	1 7/16-12	1 5/8	1 3/8	.594	4.07	2.06
16TC4-16FFX	1	1 7/16-12	1 5/8	1 3/8	.828	4.42	2.13
16TC4-20FFX	1	1 11/16-12	1 7/8	1 3/4	.828	4.42	2.19
20TC4-20FFX	1 1/4	1 11/16-12	1 7/8	1 3/4	1.062	5.17	2.37
24TC4-24FFX	1 1/2	2-12	2	2 1/4	1.25	5.17	2.32

Double Hex on Sizes 1/2" and 1 1/4" Sizes Only

Female Flat-Face “O” Seal Swivel 45°

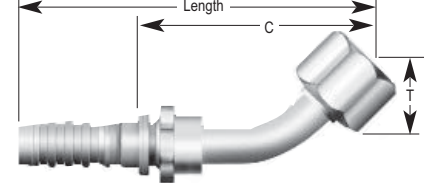

Thorburn Part #	Hose ID (in)	Thread Size	Hex A Size (in)	Hex B Size (in)	Bore Size (in)	Coupling Lgth (in)	“C” Cut-off (in)	“T” Drop Dim.
6TC4-6FFX45	3/8	1 1/16-16	1 3/16	5/8	.265	2.81	1.79	.43
8TC4-8FFX45	1/2	1 3/16-16	1 5/16	3/4	.406	4.05	2.58	.59
12TC4-12FFX45	3/4	1 3/16-12	1 3/8	1 1/8	.594	4.93	2.92	.83
12TC4-16FFX45	3/4	1 7/16-12	1 5/8	1 3/8	.594	5.44	3.43	.94
16TC4-16FFX45	1	1 7/16-12	1 5/8	1 3/8	.828	5.79	3.55	.94
16TC4-20FFX45	1	1 11/16-12	1 7/8	1 3/4	.828	6.18	3.94	1.00
20TC4-20FFX45	1 1/4	1 11/16-12	1 7/8	1 3/4	1.062	6.92	4.12	1.00
24TC4-24FFX45	1 1/2	2-12	2	2 1/4	1.28	7.54	4.74	1.07

Female Flat-Face “O” Seal Swivel 90°

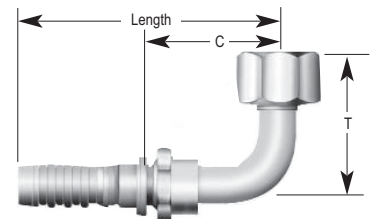

Thorburn Part #	Hose ID (in)	Thread Size	Hex A Size (in)	Hex B Size (in)	Bore Size (in)	Coupling Lgth (in)	“C” Cut-off (in)	“T” Drop Dim.
6TC4-6FFX90S	3/8	1 1/16-16	1 3/16	5/8	.265	2.68	1.60	.90
8TC4-8FFX90M	1/2	1 3/16-16	1 5/16	3/4	.406	3.46	1.88	1.15
12TC4-12FFX90S	3/4	1 3/16-12	1 3/8	1 1/8	.594	4.82	2.81	1.88
12TC4-12FFX90M	3/4	1 3/16-12	1 3/8	1 1/8	.594	4.82	2.81	2.28
12TC4-12FFX90L	3/4	1 3/16-12	1 3/8	1 1/8	.594	4.82	2.81	3.78
12TC4-16FFX90S	3/4	1 7/16-12	1 5/8	1 3/8	.594	5.38	3.37	2.21
16TC4-16FFX90S	1	1 7/16-12	1 5/8	1 3/8	.828	5.72	3.49	2.21
16TC4-16FFX90M	1	1 7/16-12	1 5/8	1 3/8	.828	5.72	3.49	2.78
16TC4-20FFX90S	1	1 11/16-12	1 7/8	1 3/4	.828	6.16	3.93	2.51
16TC4-20FFX90M	1	1 11/16-12	1 7/8	1 3/4	.828	6.16	3.93	3.93
20TC4-20FFX90S	1 1/4	1 11/16-12	1 7/8	1 3/4	1.062	6.91	4.11	2.51
20TC4-20FFX90M	1 1/4	1 11/16-12	1 7/8	1 3/4	1.062	6.91	4.11	3.09
20TC4-20FFX90L	1 1/4	1 11/16-12	1 7/8	1 3/4	1.062	6.91	4.11	5.09
24TC4-24FFX90S	1 1/2	2-12	2	2 1/4	1.281	7.61	4.81	2.70
24TC4-24FFX90M	1 1/2	2-12	2	2 1/4	1.281	7.61	4.81	3.41
24TC4-24FFX90L	1 1/2	2-12	2	2 1/4	1.281	7.61	4.81	5.54

Dimensions for reference only. Subject to change

Stainless Steel Thor-Crimp Stems for TR13 & TR15 Hose

Series VI Ferrules

Material 316



Dimensions available upon request.

Thorburn Part #	Hose ID (in)
691F-10S6	5/8
691F-12S6	3/4
691F-16S6	1
691F-20S6	1 1/4
691F-24S6	1 1/2
691F-32S6	2

Female 37° Flare (JIC) Swivel 45°

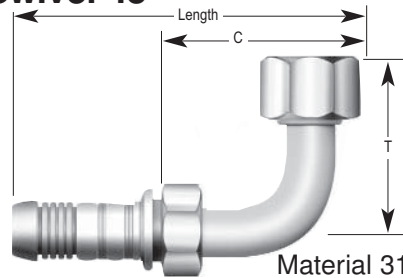

Material 316

Thorburn Part #	Hose ID (in)	Thread Size	Hex Size (in)	"T" Drop Dim (in)	Coupling Length (in)	"C" Cut-off (in)
690FJX90-10-10S6	5/8	7/8-14	1.00	1.82	5.05	3.25
690FJX90-12-12S6	3/4	1 1/16-12	1.25	1.82	5.38	3.32
690FJX90-16-16S6	1	1 5/16-12	1.50	2.14	4.97	2.75
690FJX90-20-20S6	1 1/4	1 5/8-12	2.00	3.50	7.86	5.11

"O" Ring Flange 90°

Code 62

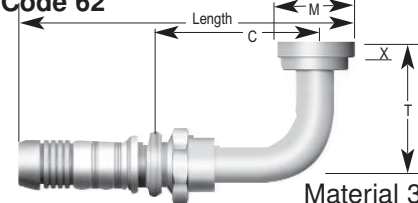

Material 316

Thorburn Part #	Hose ID (in)	Nom. Fig. Dia. (in)	"M" Dia. (in)	"T" Fig. Drop (in)	Coupling Length (in)	"C" Cut-off (in)	"X" Flange Thick.
690FLH90-12-12S6	3/4	3/4	1.63	2.44	5.25	3.19	.345
690FLH90-16-16S6	1	1	1.88	2.85	5.22	3.00	.375
690FLH90-20-20S6	1 1/4	1 1/4	2.13	3.00	6.39	3.64	.405
690FLH90-24-24S6	1 1/2	1 1/2	2.50	3.68	7.84	4.31	.495
690FLH90-32-32S6	2	2	3.13	5.12	9.07	5.24	.495

Male NPT

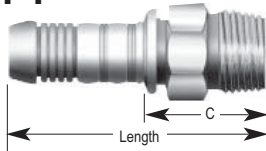

Material 316

Thorburn Part #	Hose ID (in)	Thread Size	Hex Size (in)	Bore Size (in)	Coupling Length (in)	"C" Cut-off (in)
690MP-12-12S6	3/4	3/4-14	1 1/8	.59	3.61	1.54
690MP-16-16S6	1	1-11/2	1 3/8	.83	4.17	1.95
690MP-20-20S6	1 1/4	1 1/4-11 1/2	1 13/16	1.06	4.93	2.18
690MP-24-24S6	1 1/2	1 1/2-11 1/2	2	1.23	5.76	2.20
690MP-32-32S6	2	2-1 1/2	2 1/2	1.63	6.21	2.38

"O" Ring Flange Straight

Code 62

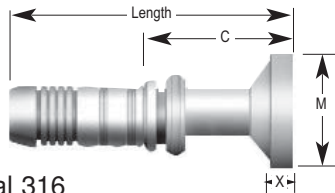

Material 316

Thorburn Part #	Hose ID (in)	Nom. Fig. Dia. (in)	"M" Fig. Dia. (in)	Coupling Length (in)	"C" Cut-off (in)	"X" Flange Thick.
690FLH-12-12S6	3/4	3/4	1.63	4.50	2.43	.345
690FLH-16-16S6	1	1	1.88	5.10	2.88	.375
690FLH-20-20S6	1 1/4	1 1/4	2.13	5.75	3.00	.405
690FLH-24-24S6	1 1/2	1 1/2	2.50	7.15	3.62	.495
690FLH-32-32S6	2	2	3.13	8.00	4.17	.495

Female Flat-Face "O" Seal Swivel Straight

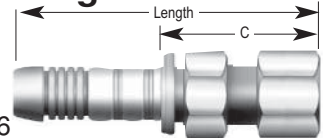

Material 316

Thorburn Part #	Hose ID (in)	Thread Size	Coupling Size (in)	"C" Cut-off Length (in)
690FFX-12-12S6	3/4	1 3/16-12	3.96	1.89
690FFX-16-16S6	1	1 7/16-12	4.37	2.15
690FFX-20-20S6	1 1/4	1 11/16-12	5.09	2.34

Female 37° Flare (JIC) Swivel

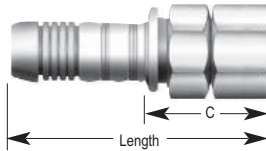

Material 316

Thorburn Part #	Hose ID (in)	Thread Size	Hex Size (in)	Bore Size (in)	Coupling Length (in)	"C" Cut-off (in)
690FJX-10-10S6	5/8	7/8-14	1	.50	2.91	1.13
690FJX-12-12S6	3/4	1 1/16-12	1 1/4	.59	3.83	1.77
690FJX-16-16S6	1	1 5/16-12	1 1/2	.83	4.15	1.93
690FJX-20-20S6	1 1/4	1 5/8-12	2	1.06	5.24	2.49
690FJX-24-24S6	1 1/2	1 7/8-12	2 3/8	1.23	6.24	2.72
690FJX-32-32S6	2	2 1/2-12	3	1.63	7.00	3.14

"O" Ring Flange 45°

Code 62

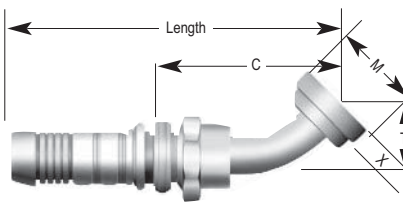

Material 316

Thorburn Part #	Hose ID (in)	Nom. Fig. Dia. (in)	"M" Fig. Dia. (in)	"T" Fig. Drop (in)	Coupling Length (in)	"C" Cut-off (in)	"X" Flange Thick.
690FLH45-12-12S6	3/4	3/4	1.63	1.13	5.59	3.52	.345
690FLH45-16-16S6	1	1	1.88	1.19	5.63	3.41	.375
690FLH45-20-20S6	1 1/4	1 1/4	2.13	1.41	6.84	4.09	.405
690FLH45-24-24S6	1 1/2	1 1/2	2.50	1.77	8.52	5.00	.495
690FLH45-32-32S6	2	2	3.13	2.51	9.96	6.14	.495

Female Flat-Face "O" Seal Swivel 45°

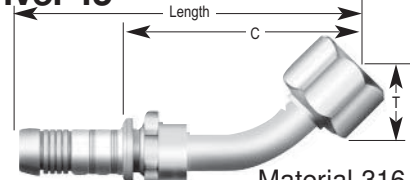

Material 316

Thorburn Part #	Hose ID (in)	Thread Size	"T" Drop Dim. (in)	Coupling Size (in)	"C" Cut-off Lgth (in)
690FFX45-10-10S6	5/8	1-14	1.02	4.91	3.13
690FFX45-12-12S6	3/4	1 3/16-12	.83	5.46	3.40
690FFX45-16-16S6	1	1 7/16-12	.94	5.67	3.45

Female 37° Flare (JIC) Swivel 45°

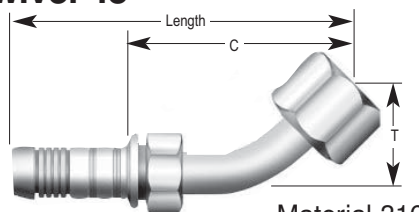

Material 316

Description	Hose ID (in)	Thread Size	Hex Size (in)	"T" Drop Dim (in)	Coupling Length (in)	"C" Cut-off (in)
690FJX45-12-12S6	3/4	1 1/16-12	1.25	1.82	5.46	3.40

Female Flat-Face "O" Seal Swivel 90°

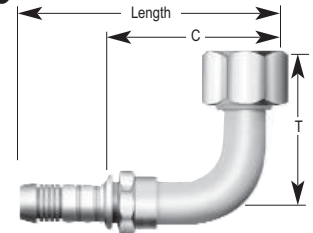

Material 316

Thorburn Part #	Hose ID (in)	Thread Size	"T" Drop Dim. (in)	Coupling Size (in)	"C" Cut-off Lgth (in)
690FFX90-10-10S6	5/8	1-14	2.09	4.48	2.70
690FFX90-12-12S6	3/4	1 3/16-12	2.28	5.36	3.30
690FFX90-16-16S6	1	1 7/16-12	2.21	5.67	3.45
690FFX90-20-20S6	1 1/4	1 11/16-12	2.51	7.86	5.11

Other sizes and shapes available upon request.

Dimensions for reference only. Subject to change

Stainless Steel Thor-Crimp Stems for TR13 & TR15 Hose

Male (JIC) 37° Flare

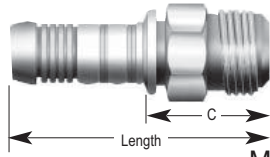

Material 316

Thorburn Part #	Hose ID (in)	Thread Size	Hex Size (in)	Bore Size (in)	Coupling Length (in)	"C" Cut-off (in)
690MJ-10-10S6	5/8	7/8-14	1 1/8	.50	3.41	1.61
690MJ-12-12S6	3/4	1 1/16-12	1 1/8	.59	3.74	1.67
690MJ-16-16S6	1	1 5/16-12	1 3/8	.83	4.11	1.89
690MJ-20-20S6	1 1/4	1 5/8-12	1 13/16	1.06	4.86	2.11
690MJ-32-32S6	2	2 1/2-12	2 1/2	1.63	6.56	2.73

"O" Ring Boss Solid Male

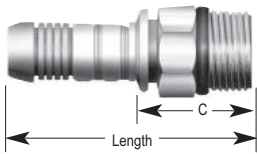

Material 316

Thorburn Part #	Hose ID (in)	Thread Size	Bore Size (in)	Stem Hex (in)	Coupling Length (in)	"C" Cut-off (in)
690MB-12-12S6	3/4	1 1/8-12	.59	1 1/4	3.52	1.45

Other sizes and shapes available upon request.

Thor-Crimp Carbon Steel Stems & Ferrules for TR13 & TR15 Hose

Series VI Ferrules

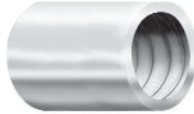

Dimensions available upon request.

Thorburn Part #	Hose ID (in)
10TC6F	5/8
12TC6F	3/4
16TC6F	1
20TC6F	1 1/4
24TC6F	1 1/2
32TC6F	2

Male NPT

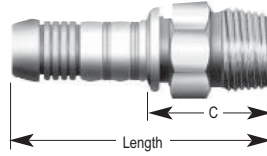

Thorburn Part #	Hose ID (in)	Thread Size	Hex Size (in)	Bore Size (in)	Coupling Length (in)	"C" Cut-off (in)
10TC6-8MP	5/8	1/2-14	1	.50	3.22	1.44
10TC6-12MP	5/8	3/4-14	1 1/8	.50	3.40	1.62
12TC6-12MP	3/4	3/4-14	1 1/8	.59	3.61	1.54
16TC6-16MP	1	1-11 1/2	1 3/8	.83	4.17	1.95
20TC6-20MP	1 1/4	1 1/4-11 1/2	1 13/16	1.06	4.93	2.18
24TC6-24MP	1 1/2	1 1/2-11 1/2	2	1.23	5.76	2.20
32TC6-32MP	2	2-11 1/2	2 1/2	1.63	6.21	2.38

"O" Ring Boss Solid Male

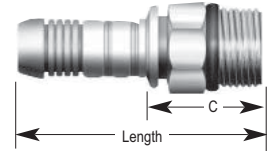

Thorburn Part #	Hose ID (in)	Thread Size	Bore Size (in)	Stem Hex (in)	Coupling Length (in)	"C" Cut-off (in)
10TC6-10MB	5/8	7/8-14	.50	1	3.16	1.38
10TC6-12MB	5/8	1 1/8-12	.50	1 1/4	3.13	1.35
12TC6-12MB	3/4	1 1/8-12	.59	1 1/4	3.52	1.45

Male (JIC) 37° Flare

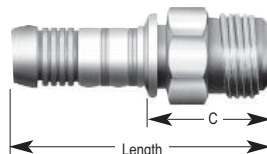

Thorburn Part #	Hose ID (in)	Thread Size	Hex Size (in)	Bore Size (in)	Coupling Length (in)	"C" Cut-off (in)
10TC6-10MJ	5/8	7/8-14	1 1/8	.50	3.41	1.61
10TC6-12MJ	5/8	1 1/16-12	1 1/8	.50	3.50	1.67
12TC6-12MJ	3/4	1 1/16-12	1 1/8	.59	3.74	1.67
16TC6-16MJ	1	1 5/16-12	1 3/8	.83	4.11	1.89
20TC6-20MJ	1 1/4	1 5/8-12	1 13/16	1.06	4.86	2.11
32TC6-32MJ	2	2 1/2-12	2 1/2	1.63	6.56	2.73

Female 37° Flare (JIC) Swivel

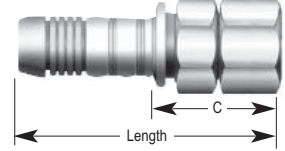

Thorburn Part #	Hose ID (in)	Thread Size	Hex Size (in)	Bore Size (in)	Coupling Length (in)	"C" Cut-off (in)
10TC6-10FJX	5/8	7/8-14	1	.50	2.91	1.13
10TC6-12FJX	5/8	1 1/16-12	1 1/4	.50	3.53	1.74
12TC6-12FJX	3/4	1 1/16-12	1 1/4	.59	3.83	1.77
12TC6-16FJX	3/4	1 5/16-12	1 1/2	.59	3.90	1.84
16TC6-16FJX	1	1 15/16-12	1 1/2	.83	4.15	1.93
20TC6-20FJX	1 1/4	1 5/8-12	2	1.06	5.24	2.49
20TC6-24FJX	1 1/4	1 7/8-12	2 3/8	1.06	5.31	2.56
24TC6-24FJX	1 1/2	1 7/8-12	2 3/8	1.23	6.24	2.72
32TC6-32FJX	2	2 1/2-12	3	1.63	7.00	3.14

Female 37° Flare (JIC) Swivel 45°

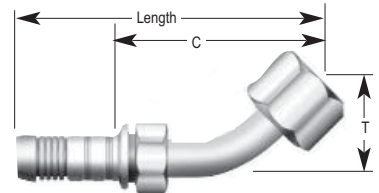

Description	Hose ID (in)	Thread Size	Hex Size (in)	"T" Drop Dim (in)	Coupling Length (in)	"C" Cut-off (in)
10TC6-12FJX45	5/8	1 1/16-12	1.25	1.16	5.16	3.38
12TC6-12FJX45	3/4	1 1/16-12	1.25	1.82	5.46	3.40

Female 37° Flare (JIC) Swivel 90°

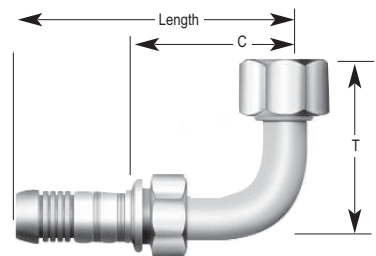

Thorburn Part #	Hose ID (in)	Thread Size	Hex Size (in)	"T" Drop Dim (in)	Coupling Length (in)	"C" Cut-off (in)
10TC6-10FJX90S	5/8	7/8-14	1.00	1.82	5.05	3.25
10TC6-12FJX90S	5/8	1 1/16-12	1.25	2.35	4.73	2.95
12TC6-12FJX90	3/4	1 1/16-12	1.25	1.82	5.38	3.32
12TC6-16FJX90	3/4	1 5/16-12	1.50	2.14	5.86	3.80
16TC6-16FJX90	1	1 5/16-12	1.50	2.85	4.97	2.75
20TC6-20FJX90M	1 1/4	1 5/8-12	2.00	3.50	7.86	5.11

Dimensions for reference only. Subject to change

“O” Ring Flange Straight

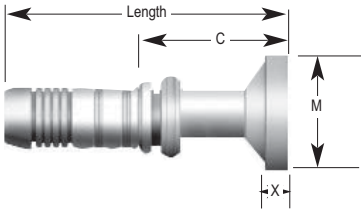

Thorburn Part #	Hose ID (in)	Nom. Fig. Dia. (in)	“M” Fig. Dia. (in)	Coupling Length (in)	“C” Cut-off (in)	“X” Flange Thick.
CODE 61						
10TC6-10FL	5/8	5/8	1.35	4.50	2.40	.265
10TC6-12FL	5/8	3/4	1.50	4.50	2.43	.265
12TC6-12FL	3/4	3/4	1.50	4.50	2.43	.265
16TC6-16FL	1	1	1.75	5.10	2.88	.315
20TC6-20FL	1 1/4	1 1/4	2.00	5.75	3.12	.315
20TC6-24FL	1 1/4	1 1/2	2.38	6.25	3.30	.315
24TC6-24FL	1 1/2	1 1/2	2.38	7.15	3.98	.315
24TC6-32FL	1 1/2	2	2.81	8.00	4.18	.375
32TC6-32FL	2	2	2.81	8.00	4.18	.375
-16FL Maximum 5,000 PSI -20FL Maximum 4,000 PSI -24FL Maximum 3,000 PSI						
CODE 62						
12TC6-12FLH	3/4	3/4	1.63	4.50	2.43	.345
16TC6-12FLH	1	3/4	1.63	5.10	2.88	.345
16TC6-16FLH	1	1	1.88	5.10	2.88	.375
16TC6-20FLH	1	1 1/4	2.13	5.18	2.96	.405
20TC6-20FLH	1 1/4	1 1/4	2.13	5.75	3.00	.405
20TC6-24FLH	1 1/4	1 1/2	2.50	6.25	3.50	.495
24TC6-24FLH	1 1/2	1 1/2	2.50	7.15	3.62	.495
24TC6-32FLH	1 1/2	2	3.13	7.76	4.17	.495
32TC6-32FLH	2	2	3.13	8.00	4.17	.495

“O” Seal Flange 22°

(Code 62 - SAE J518)

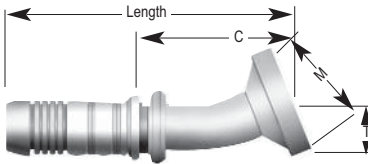

Thorburn Part #	Hose ID (in)	Nom. Fig. Dia. (in)	“M” Fig. Dia. (in)	“T” Drop Dim. (in)	Coupling Length (in)	“C” Cut-off (in)	X Flange Thickness
16TC6-16FLH22	1	1	1.88	.44	5.94	3.72	.375
20TC6-20FLH22	1 1/4	1 1/4	2.13	.61	7.19	4.44	.405
20TC6-24FLH22	1 1/4	1 1/2	2.50	.68	7.37	4.62	.495
24TC6-24FLH22	1 1/2	1 1/2	2.50	.68	7.37	4.62	.495

Available upon request.

“O” Ring Flange 45°

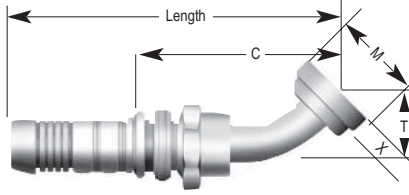

Thorburn Part #	Hose ID (in)	Nom. Fig. Dia. (in)	“M” Fig. Dia. (in)	“T” Drop (in)	Coupling Length (in)	“C” Cut-off (in)	“X” Flange Thick.
CODE 61							
10TC6-10FL45	5/8	5/8	1.35	1.02	5.45	3.25	.265
10TC6-12FL45	5/8	3/4	1.50	1.00	5.50	3.25	.265
12TC6-12FL45	3/4	3/4	1.50	1.13	5.59	3.52	.265
16TC6-16FL45	1	1	1.75	1.19	5.63	3.41	.315
20TC6-20FL45	1 1/4	1 1/4	2.00	1.41	6.85	4.10	.315
24TC6-24FL45	1 1/2	1 1/2	2.38	1.77	8.52	5.00	.315
32TC6-32FL45	2	2	2.81	2.51	9.96	6.14	.375
-16FL Maximum 5,000 PSI -20FL Maximum 4,000 PSI -24FL Maximum 3,000 PSI							
CODE 62							
12TC6-12FLH45	3/4	3/4	1.63	1.13	5.59	3.52	.345
16TC6-16FLH45	1	1	1.88	1.19	5.63	3.41	.375
16TC6-20FLH45	1	1 1/4	2.13	2.41	6.84	4.09	.405
20TC6-20FLH45	1 1/4	1 1/4	2.13	1.41	6.84	4.09	.405
20TC6-24FLH45	1 1/4	1 1/2	2.50	1.55	6.98	4.23	.495
24TC6-24FLH45	1 1/2	1 1/2	2.50	1.77	8.52	5.00	.495
32TC6-32FLH45	2	2	3.13	2.51	9.96	6.14	.495

“O” Seal Flange 30°

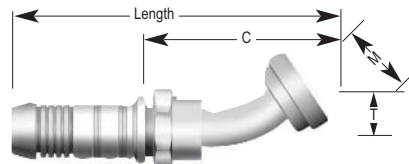

Thorburn Part #	Hose ID (in)	Nom. Fig. Dia. (in)	“M” Fig. Dia. (in)	“T” Drop Dim. (in)	Coupling Length (in)	“C” Cut-off (in)	X Flange Thickness
Code 61							
12TC6-12FL30	3/4	3/4	1.50	.64	5.44	3.38	.265
16TC6-16FL30	1	1	1.75	.84	6.05	3.83	.315
20TC6-20FL30	1 1/4	1 1/4	2.00	.88	7.28	4.53	.315
24TC6-24FL30	1 1/2	1 1/2	2.38	1.11	9.08	5.56	.315
Code 62							
12TC6-12FLH30	3/4	3/4	1.63	.64	5.44	3.38	.345
16TC6-16FLH30	1	1	1.88	.84	6.05	3.83	.375
20TC6-20FLH30	1 1/4	1 1/4	2.13	.88	7.13	4.38	.405
20TC6-24FLH30	1 1/4	1 1/2	2.50	1.11	8.87	5.34	.495
24TC6-24FLH30	1 1/2	1 1/2	2.50	1.11	8.87	5.34	.495
32TC6-32FLH30	2	2	3.13	1.57	10.45	6.63	.495

Available upon request.

“O” Ring Flange 90°

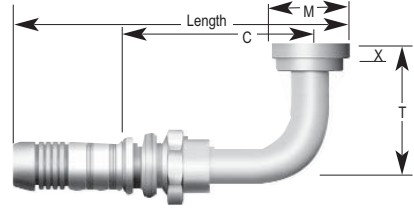

Thorburn Part #	Hose ID (in)	Nom. Fig. Dia. (in)	“M” Fig. Dia. (in)	“T” Drop (in)	Coupling Length (in)	“C” Cut-off (in)	“X” Flange Thick.
CODE 61							
10TC6-10FL90	5/8	5/8	1.35	2.40	5.10	3.00	.265
10TC6-12FL90	5/8	3/4	1.50	2.40	5.10	3.00	.265
12TC6-12FL90	3/4	3/4	1.50	2.44	5.25	3.19	.265
16TC6-16FL90	1	1	1.75	3.00	5.33	3.00	.315
20TC6-16FL90	1 1/4	1	2.00	2.50	5.90	3.15	.315
20TC6-20FL90	1 1/4	1 1/4	2.00	3.00	6.39	3.64	.315
24TC6-24FL90	1 1/2	1 1/2	2.38	3.68	7.84	4.31	.315
32TC6-32FL90	2	2	2.81	5.12	9.07	5.24	.375
-16FL Maximum 5,000 PSI -20FL Maximum 4,000 PSI -24FL Maximum 3,000 PSI							
CODE 62							
12TC6-12FLH90	3/4	3/4	1.63	2.44	5.25	3.19	.345
12TC6-16FLH90	3/4	1	1.88	2.25	5.25	3.19	.375
16TC6-12FLH90	1	3/4	1.63	2.37	5.35	3.14	.345
16TC6-16FLH90	1	1	1.88	2.85	5.22	3.00	.375
16TC6-20FLH90	1	1 1/4	2.13	3.00	6.39	3.64	.405
16TC6-24FLH90	1	1 1/2	2.50	2.88	5.33	3.11	.495
20TC6-20FLH90	1 1/4	1 1/4	2.13	3.00	6.39	3.64	.405
20TC6-20FLH90L	1 1/4	1 1/4	2.50	4.75	6.98	3.64	.405
20TC6-20FLH90XL	1 1/4	1 1/4	2.50	6.00	6.39	3.64	.405
20TC6-24FLH90	1 1/4	1 1/2	2.50	3.19	6.39	3.64	.495
24TC6-24FLH90	1 1/2	1 1/2	2.50	3.68	7.84	4.31	.495
24TC6-32FLH90	1 1/2	2	3.13	4.00	7.84	4.31	.495
32TC6-32FLH90	2	2	3.13	5.12	9.07	5.24	.495

“O” Seal Flange 60°

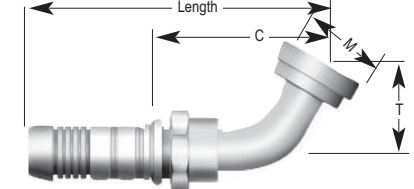

Thorburn Part #	Hose ID (in)	Nom. Fig. Dia. (in)	“M” Fig. Dia. (in)	“T” Drop Dim. (in)	Coupling Length (in)	“C” Cut-off (in)	X Flange Thickness
Code 61							
12TC6-12FL60	3/4	3/4	1.50	1.48	5.57	3.50	.265
16TC6-16FL60	1	1	1.75	1.62	6.36	4.14	.315
20TC6-20FL60	1 1/4	1 1/4	2.00	1.98	7.64	4.89	.315
24TC6-24FL60	1 1/2	1 1/2	2.38	2.48	9.40	5.87	.315
Code 62							
12TC6-12FLH60	3/4	3/4	1.63	1.48	5.57	3.50	.345
16TC6-16FLH60	1	1	1.88	1.62	6.36	4.14	.375
20TC6-20FLH60	1 1/4	1 1/4	2.13	1.98	7.65	4.90	.405
20TC6-24FLH60	1 1/4	1 1/2	2.50	2.48	9.40	5.88	.495
24TC6-24FLH60	1 1/2	1 1/2	2.50	2.48	9.40	5.88	.495
32TC6-32FLH60	2	2	3.13	3.43	11.24	7.42	.495

Available upon request.

Female Flat-Face "O" Seal Swivel Straight

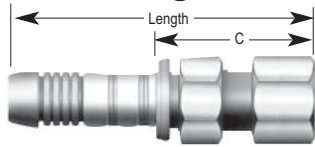

Thorburn Part #	Hose ID (in)	Thread Size	Coupling Size (in)	"C" Cut-off Length (in)
10TC6-10FFX	5/8	1-14	3.58	1.80
12TC6-12FFX	3/4	1 3/16-12	3.96	1.89
16TC6-16FFX	1	1 7/16-12	4.37	2.15
16TC6-20FFX	1	1 11/16-12	5.09	2.34
20TC6-20FFX	1 1/4	1 11/16-12	5.09	2.34

Hose Length Extender



Thorburn Part #	Hose ID (in)
16TC6-16HLE	1
20TC6-20HLE	1 1/4
24TC6-24HLE	1 1/2
32TC6-32HLE	2

Female Flat-Face "O" Seal Swivel 45°

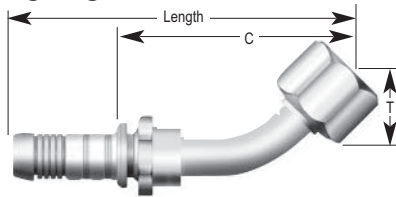

Thorburn Part #	Hose ID (in)	Thread Size	"T" Drop. Dim. (in)	Coupling Size (in)	"C" Cut-off Lgth (in)
10TC6-10FFX45	5/8	1-14	1.02	4.91	3.13
12TC6-12FFX45	3/4	1 3/16-12	.83	5.46	3.40
16TC6-16FFX45	1	1 7/16-12	.94	5.67	3.45

Female Flat-Face "O" Seal Swivel 90°

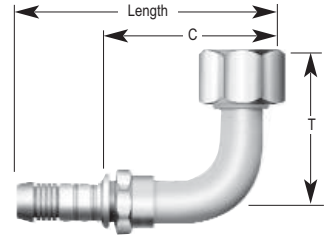

Thorburn Part #	Hose ID (in)	Thread Size	"T" Drop. Dim. (in)	Coupling Size (in)	"C" Cut-off Lgth (in)
10TC6-10FFX90M	5/8	1-14	2.09	4.48	2.70
10TC6-10FFX90L	5/8	1-14	3.78	4.48	2.70
12TC6-12FFX90	3/4	1 3/16-12	2.28	5.36	3.30
16TC6-16FFX90M	1	1 7/16-12	2.78	5.71	3.49
16TC6-16FFX90S	1	1 7/16-12	2.21	5.67	3.45
16TC6-20FFX90M	1	1 11/16-12	3.09	6.19	3.97
20TC6-20FFX90S	1 1/4	1 11/16-12	2.51	7.86	5.11

Aqua Therm-A Model TPWBLU

- "Non Marking"
- 3000 psi



RECOMMENDED FOR:

On hot and cold water high pressure cleaning equipment where heavy duty service is required. Thorburn's "Aqua Therm-A" model TPWBLU was specially designed for applications that require non-marking cover.

WARNING: Not recommended for steam service

Couplings: "Crimp Type" See following page.
Bend restrictors recommended to extend service.

Construction

Tube: Black oil, heat and detergent resistant Buna "N" blend

Reinforcement: High tensile braided steel wire

Cover: Neoprene specially compounded to be non marking, abrasion, heat, ozone and weather resistant. Not resistant to animal fats

Temperature: -40° F. to 250° F.
(-40° C to 122° C)

Lengths: Up to 150 ft. available

Part Number	Hose ID Inches	Hose OD Inches	Design Pressure PSI	Min Burst Pressure PSI	Min Bend Radius Inches	Weight LBS/100FT
TPWBLU04	1/4	1/2	3000	12000	2	13
TPWBLU06	3/8	5/8	3000	12000	2.5	18
TPWBLU08	1/2	20/32	3000	12000	3.5	25

Aqua Therm-B Model TPWBLK

- Animal Fat & Oil Resistant
- 3000 psi

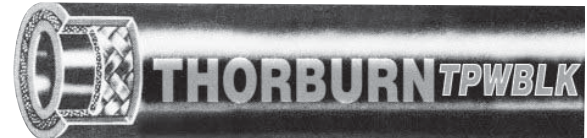

RECOMMENDED FOR:

On hot and cold water high pressure cleaning equipment where heavy duty service is required. Thorburn's "Aqua Therm-B" model TPWBLK was specially designed for applications that require a cover that is resistant to animal fats.

WARNING: Not recommended for steam service

Couplings: "Crimp Type" See following page.
Bend restrictors recommended to extend service.

Construction

Tube: Black oil, heat and detergent resistant Buna "N" blend

Reinforcement: High tensile braided steel wire

Cover: Neoprene specially compounded to be resistant to animal fats, abrasion, heat, ozone and weather resistant. Not resistant to

Temperature: -40° F. to 212° F.
(-40° C to 100° C)

Lengths: Up to 150 ft. available

Part Number	Hose ID Inches	Hose OD Inches	Design Pressure PSI	Min Burst Pressure PSI	Min Bend Radius Inches	Weight LBS/100FT
TPWBLK04	1/4	0.53	3000	12000	4	14
TPWBLK06	3/8	0.68	3000	12000	5	23
TPWBLK08	1/2	0.82	2500	10000	7	28

Aqua Therm-C Model TPWHT

Super Heated Water 350°F @ 350psi (Super Heated Water)

RECOMMENDED FOR:

Hot and cold high pressure cleaning equipment where heavy duty service is required. Thorburn's "Aqua Therm-C" model TPWHT was specially designed for applications that require cleaning with super-heated water at 350° at 350 psi.

WARNING: Not recommended for steam service

Couplings: "Crimp Type" See below.
Bend restrictors recommended to extend service.



Construction

Tube: Black EPDM heat resistant synthetic rubber

Reinforcement: High tensile braided steel wire
Cover: Hypalon cover which provides abrasion, ozone and oil resistance

Temperature: -40° F to 350° F.
(-40° C to 177° C)

Lengths: Up to 150 ft. available

Part Number	Hose ID Inches	Hose OD Inches	Design Pressure PSI	Min Burst Pressure PSI	Min Bend Radius Inches	Weight LBS/100FT
TPWHT06	3/8	0.68	3000	12000	2	19

Typical Crimp Couplings Plated Steel

Rigid Male NPT

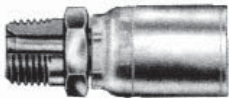

Code MP

Male Swivel



Code MPX

37° Female Swivel



Code FJX

Karcher (M22 x 1.51) Swivel

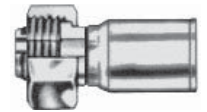

Code KX

Couplings also available in stainless steel.

Typical PressureWasher Quick Coupling Brass also available in Carbon Steel & Stainless Steel

Bend Restrictor

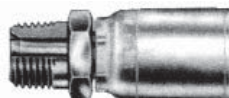

Code BR

Female Nipple

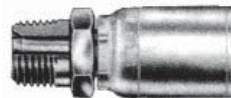

Code QNF

Female Coupling

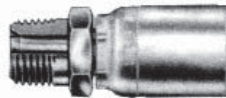

Code QCF

Markets	Applications
Industrial Cleaning Markets	Pressure wash engines, equipment, tanks, buildings, and roof cleaning, etc.
Food Industry	Wash down of food processing facilities and equipment.
Construction Industry	High pressure cleaning and degreasing.
Marine	Boat Cleaning
Agriculture	Pressure wash engines, farm equipment, tanks and buildings

How to order Thorburn Pressure Washer Hose Assembly

Hose Size	1st Material	2nd Material	O.A.L. ft.	Options
TPWHT06	MPXC	MPC	50	BR

Description of Hose Assembly

Thorburn Model TPWHT06 at 3/8" size c/w 3/8" Male Rigid Swivel 50' O.A.L. c/w Bend Restrictor.

Material Codes
316SS = S6
Carbon Steel = C



Elastomeric Waterblast Hose Assemblies

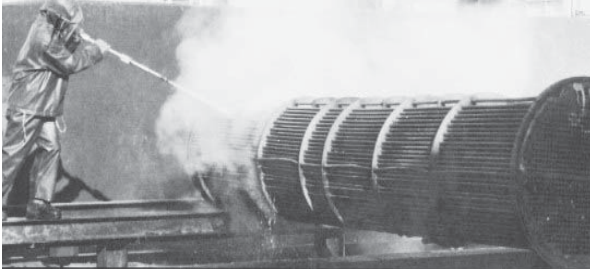

Thorburn's Model N23TWX elastomeric hose assemblies are designed for extremely high pressure water cleaning equipment. Thorburn tests each N23TWX assembly to 15000 psi, tags and serializes for complete traceability. At Thorburn, we say "Quality goes in before the name goes on". Thorburn Model N23TWX hose assemblies are registered for 10,000 psi service as per ASME B31.1. Their elastomeric materials have a radiation resistance of 6×10^7 Roentgens. This hose is to be used for waterblast purposes only.

Temperature range: -40°F to 212°F
-40°C to 100°C

N23TWX Ultra High Pressure Hose

CONSTRUCTION

Tube: Special blend of smooth black Butadiene Acrylo-Nitrile synthetic rubber.

Reinforcement: Four layers of high tensile spiraled steel wire with one high tensile braided wire over a layer of calendered polyester.

Cover: Black Polychlorprene blend providing excellent abrasion and ozone resistance.

Couplings: Factory assembled crimp type quick coupling in carbon steel or stainless steel.

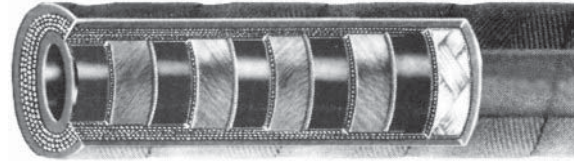

WARNING: IT IS NOT RECOMMENDED TO USE NPT THREADS GREATER THAN 10,000 PSI SERVICE

Part Number	Hose ID Inches	Hose OD Inches	Design Pressure PSI	Min Burst Pressure PSI	Min Bend Radius Inches	Weight LBS/100FT
N23TWX04	1/4	0.79	10000	40000	5	55
N23TWX06	3/8	0.81	10000	40000	6	60
N23TWX08	1/2	1.16	10000	40000	8	115



HOW TO ORDER THORBURN N23TWX HOSE ASSEMBLIES

HOSE SIZE	1ST END COUPLING SIZE	1ST END MATERIAL	2ND END COUPLING SIZE	2ND END MATERIAL	LENGTH INCHES
N23TWX08	8MP	S6	8MP	S6	600

For carbon steel material code C

Above 10,000 psi Thorburn recommends male cone and threaded or reverse high pressure connections.

Description:

1/2" N23TWX hose c/w 1/2" male pipe NPT in 316SS, other end 1/2" male pipe NPT in 316SS, 600" overall length. Also available with quick couplings.

Medium Pressure Teflon Lined Hoses

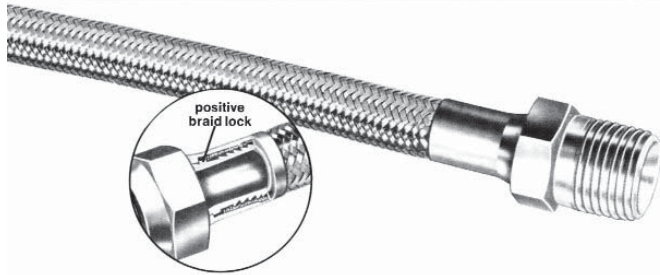

SMOOTH BORE T46-SAE (100R14A) T47-SAE (100R14B)

Thorburn T series is an ideal hose that solves demanding problems in diverse applications such as chemical transfer, steel processing, paint spraying, fuel and lubricant handling, hydraulic systems, plastic molding machines, food processing, marine and transportation industries.

Hose Construction

General purpose assemblies

Thorburn T46 series A has a smooth innercore of extruded white Teflon resin with type 304 stainless steel wire braid reinforcement. Meets SAE 100R14A

Conductive assemblies

Thorburn T47 series B has a precisely controlled amount of carbon black added to the inner 15% of the Teflon innercore. This homogeneous material provides a continuous conductive path to the metal end fittings, to bleed off static electricity in high flow applications. Meets SAE 100R14B

Temperature Range

-65oF to 450oF (-54oC to 232oC) for continuous service. -100oF to 500oF (-73oC to 260oC) for intermittent service only.

Standards

Meets requirements of SAE 100R14A, SAE 100R14B Accepted by U.S. and Canadian Coast Guard.

Rating Pressure

Sizes through 5/8" I.D. Full vacuum

Long Lengths

Up to 2000 feet upon request

Special note: PTFE standard core, PFA, FEP teflon core construction available upon request.

Part Number	Hose ID Inches	Hose OD Inches	Design Press PSI		Min Burst Press PSI	Min Bend Radius Inches	Weight LBS/FT
			Hydraulic	Steam			
T46-4 / T47-4	3/16	.31	1500	200	10000	2.00	.07
T46-5 / T47-5	1/4	.38	1500	200	9000	3.00	.10
T46-6 / T47-6	5/16	.44	1500	200	8000	4.00	.11
T46-8 / T47-8	13/32	.54	1000	200	6000	5.25	.13
T46-10 / T47-10	1/2	.63	800	200	6000	6.50	.17
T46-12 / T47-12	5/8	.76	800	200	5000	7.75	.19
T46-16 / T47-16	7/8	1.01	800	200	3500	9.00	.28

How to Order Thorburn T46/T47 Hose Assemblies

HOSE TYPE	Hose Size in 1/16"	Coupling Type	Coupling Assembly No. & Connection Size in 1/16" for each end		Assembly Length (in)	Additional Fractional Length in 1/8"
			1ST END	2ND END		
T46	8	R	70-8	71-8	036	3

PART NUMBER DETAILS

Hose Type: T46 - T46 Teflon hose part no.

Hose Size: - Nominal hose size in 1/16".

Coupling Type: R - All types (R = reusable)

Coupling Assembly No.: Located in box above Coupling illustration (For 1st and 2nd end)

Connection Size: Located in column after Coupling part no. (For 1st and 2nd end)

Assembly Length: Whole inches (use three digits)

Additional Fractional Length: In 1/8" increments

KEY TOP ABOVE EXAMPLE

T46: T46 Teflon hose

8: Nominal hose size.

R: Reusable couplings

70-8: Pipe male - 8 connection size

71-8: JIC 37° Flare swivel - 8 connection size

036: Assembly length, 36"

3: 3/8" fractional length

To order bulk hose or couplings, order by Part No.

Couplings for Special Purpose Hose Assemblies

Male Pipe Assembly No. 70

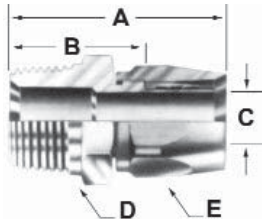

Part Number	Hose Size	Conn Size	Thread NPTF	A	Cut Factor B	Nom ID C	Hex D	Hex E	F
T200-4-2RMP	4	2	1/8-27	1.38	0.92	0.16	0.56	0.56	N/A
T200-4-4RMP	4	4	1/4-18	1.54	1.08	0.16	0.56	0.56	N/A
T200-5-4RMP	5	4	1/4-18	1.58	1.07	0.23	0.62	0.62	N/A
T200-6-4RMP	6	4	1/4-18	1.66	1.14	0.28	0.69	0.69	N/A
T200-6-6RMP	6	6	3/8-18	1.66	1.13	0.28	0.69	0.69	N/A
T200-6-8RMP	6	8	3/8-18	1.85	1.22	0.38	0.88	0.88	N/A
T200-8-8RMP	8	8	1/2-14	2.10	1.46	0.38	0.88	0.88	N/A
T200-8-10RMP	8	10	1/2-14	2.13	1.46	0.46	1.00	1.00	N/A
T200-12-12RMP	12	12	3/4-14	2.26	1.61	0.58	1.12	1.12	N/A
T200-16-16RMP	16	16	1-11 1/2	2.50	1.87	0.83	1.38	1.38	N/A

JIC 37° Flare Swivel Assembly No. 71

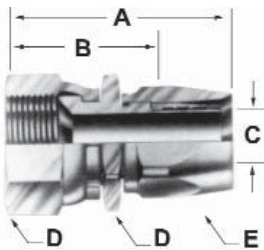

Part Number	Hose Size	Conn Size	Thread NPTF	A	Cut Factor B	Nom ID C	Hex D	Hex E	F
T200-4-4RFJX	4	4	7/16-20	1.58	1.12	0.16	0.56	0.56	N/A
T200-5-5RFJX	5	5	1/2-20	1.68	1.17	0.23	0.62	0.62	N/A
T200-6-6RFJX	6	6	9/16-18	1.76	1.24	0.28	0.69	0.69	N/A
T200-6-8RFJX	6	8	3/4-16	1.85	1.33	0.28	0.88	0.69	N/A
T200-8-8RFJX	8	8	3/4-16	1.98	1.36	0.38	0.88	0.88	N/A
T200-10-10RFJX	10	10	7/8-14	2.22	1.55	0.46	1.00	1.00	N/A
T200-12-12RFJX	12	12	1 1/16-12	2.33	1.68	0.58	1.25	1.12	N/A
T200-16-16RFJX	16	16	1 5/16-12	2.54	1.91	0.83	1.50	1.38	N/A

45° Elbow JIC 37° Flare Swivel Assembly No. 72

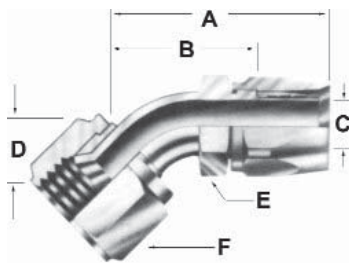

Part Number	Hose Size	Conn Size	Thread NPTF	A	Cut Factor B	Nom ID C	D	Hex E	Hex F
T200-4-4RFJX45	4	4	7/16-20	1.51	1.05	0.16	0.33	0.56	0.56
T200-5-5RFJX45	5	5	1/2-20	1.62	1.11	0.23	0.36	0.62	0.62
T200-6-6RFJX45	6	6	9/16-18	1.72	1.20	0.28	0.39	0.69	0.69
T200-6-8RFJX45	6	8	3/4-16	2.12	1.59	0.28	0.55	0.69	0.88
T200-8-8RFJX45	8	8	3/4-16	2.27	1.64	0.38	0.55	0.81	0.88
T200-10-10RFJX45	10	10	7/8-14	2.46	1.79	0.46	0.64	0.94	1.00
T200-12-12RFJX45	12	12	1 1/16-12	2.86	2.21	0.58	0.78	1.12	1.25
T200-16-16RFJX45	16	16	1 5/16-12	3.12	2.50	0.83	0.89	1.38	1.50

90° Elbow JIC 37° Flare Swivel Assembly No. 73

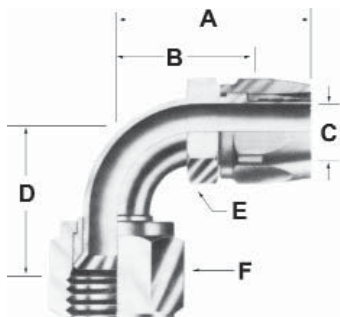

Part Number	Hose Size	Conn Size	Thread NPTF	A	Cut Factor B	Nom ID C	D	Hex E	Hex F
T200-4-4RFJX90	4	4	7/16-20	1.41	0.95	0.16	0.68	0.56	0.56
T200-5-5RFJX90	5	5	1/2-20	1.52	1.00	0.23	0.77	0.62	0.62
T200-6-6RFJX90	6	6	9/16-18	1.62	1.10	0.28	0.85	0.69	0.69
T200-6-8RFJX90	6	8	3/4-16	1.84	1.25	0.28	1.09	0.69	0.88
T200-8-8RFJX90	8	8	3/4-16	2.03	1.41	0.38	1.09	0.81	0.88
T200-10-10RFJX90	10	10	7/8-14	2.16	1.49	0.46	1.23	0.94	1.00
T200-12-12RFJX90	12	12	1 1/16-12	2.82	2.17	0.58	1.82	1.12	1.25
T200-16-16RFJX90	16	16	1 5/16-12	3.10	2.49	0.83	2.14	1.38	1.50

Couplings for Special Purpose Hose Assemblies

SAE 45° Flare Swivel

Assembly No. 74

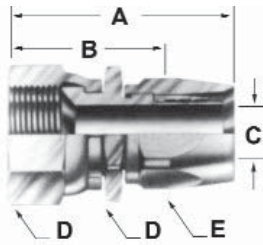

Part Number	Hose Size	Conn Size	Thread Size	A	Cut Factor B	Nom ID C	Hex D	Hex E	Hex F
T245-4-4RFJX	4	4	7/16-20	1.38	1.58	1.12	0.16	0.56	N/A
T245-5-5RFJX	5	5	1/2-20	1.54	1.68	1.17	0.23	0.62	N/A
T245-6-6RFJX	6	6	5/8-18	1.58	1.80	1.28	0.28	0.75	N/A
T245-6-8RFJX	6	8	3/4-16	1.66	1.85	1.33	0.28	0.88	N/A
T245-8-8RFJX	8	8	3/4-16	1.66	1.98	1.36	0.38	0.88	N/A
T245-10-10RFJX	10	10	7/8-14	1.85	2.22	1.55	0.46	1.00	N/A
T245-12-12RFJX	12	12	1 1/16-14	2.10	2.33	1.67	0.58	1.25	N/A

45° Elbow SAE 45° Flare Swivel

Assembly No. 75

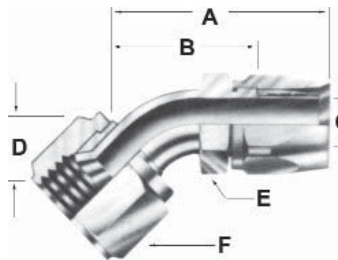

Part Number	Hose Size	Conn Size	Thread Size	A	Cut Factor B	Nom ID C	Hex D	Hex E	F
T245-4-4RFJX45	4	4	7/16-20	1.51	1.05	0.16	0.33	0.56	0.56
T245-5-5RFJX45	5	5	1/2-20	1.62	1.11	0.23	0.36	0.62	0.62
T245-6-6RFJX45	6	6	5/8-18	1.72	1.20	0.28	0.39	0.69	0.75
T245-6-8RFJX45	6	8	3/4-16	2.12	1.59	0.28	0.55	0.69	0.88
T245-8-8RFJX45	8	8	3/4-16	2.27	1.64	0.38	0.55	0.81	0.88
T245-10-10RFJX45	10	10	7/8-14	2.46	1.79	0.46	0.64	0.94	1.00
T245-12-12RFJX45	12	12	1 1/16-14	2.86	2.21	0.58	0.78	1.12	1.25

90° Elbow SAE 45° Flare Swivel

Assembly No. 76

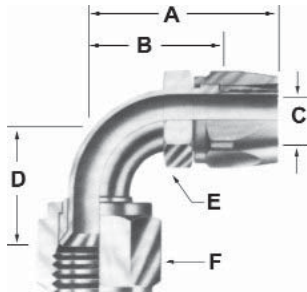

Part Number	Hose Size	Conn Size	Thread Size	A	Cut Factor B	Nom ID C	D	Hex E	Hex F
T245-4-4RFJX90	4	4	7/16-20	1.41	0.95	0.16	0.68	0.56	0.56
T245-5-5RFJX90	5	5	1/2-20	1.52	1.00	0.23	0.77	0.62	0.62
T245-6-6RFJX90	6	6	5/8-18	1.62	1.10	0.28	0.85	0.69	0.75
T245-6-8RFJX90	6	8	3/4-16	1.84	1.25	0.28	1.09	0.69	0.88
T245-8-8RFJX90	8	8	3/4-16	2.03	1.41	0.38	1.09	0.81	0.88
T245-10-10RFJX90	10	10	7/8-14	2.16	1.49	0.47	1.23	0.94	1.00
T245-12-12RFJX90	12	12	1 1/16-14	2.80	2.19	0.59	1.82	1.12	1.25

Straight Tube

Assembly No. 77

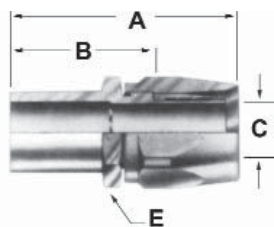

Part Number	Hose Size	Conn Size	Thread Size	A	Cut Factor B	Nom ID C	D	Hex E	F
T270-8-8RJT	8	8	11/16-20	2.08	1.44	0.38	N/A	0.81	N/A
T270-8-10RJT	8	10	13/16-18	2.08	1.44	0.38	N/A	0.81	N/A
T270-10-10RJT	10	10	13/16-18	2.16	1.49	0.46	N/A	0.94	N/A
T270-12-12RJT	12	12	1-18	2.42	1.76	0.58	N/A	1.00	N/A

Tube accepts Spherical Sleeve No. 1211 and Air Brake Nut No. 4035 per SAE J246

Compression Air Brake Male

Assembly No. 78

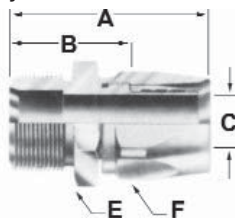

Part Number	Hose Size	Conn Size	Thread Size	A	Cut Factor B	Nom ID C	D	Hex E	Hex F
T270-8-8RCM	8	8	11/16-20	1.68	1.04	0.38	N/A	0.81	N/A
T270-10-8RCM	10	8	11/16-20	1.79	1.12	0.46	N/A	0.94	N/A
T270-10-10RCM	10	10	13/16-18	1.85	1.18	0.46	N/A	0.94	N/A
T270-12-12RCM	12	12	1-18	2.08	1.42	0.58	N/A	1.06	N/A

Use with Spherical Sleeve No. 1211 and Air Brake Nut No. 4035 per SAE J246

Couplings for Special Purpose Hose Assemblies

SAE 45° Inverted Flare Swivel

Assembly No. 74

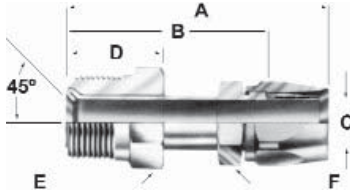

Part Number	Hose Size	Conn Size	Thread NPTF	A	Cut Factor B	Nom ID C	D	Hex E	Hex F
T265-4-4RIM	4	4	7/16-24	2.12	1.66	0.16	0.56	0.44	0.56
T265-5-5RIM	5	5	1/2-20	2.17	1.66	0.22	0.62	0.50	0.62
T265-6-5RIM	6	5	1/2-20	2.21	1.69	0.28	0.62	0.50	0.69
T265-6-6RIM	6	6	5/8-18	2.21	1.69	0.28	0.66	0.62	0.69
T265-8-8RIM	8	8	3/4-18	2.56	1.84	0.38	0.74	0.75	0.81
T265-10-10RIM	10	10	7/8-18	2.78	2.11	0.46	0.80	0.88	0.94
T265-12-12RIM	12	12	1 1/16-16	3.03	2.37	0.58	0.88	1.06	1.12

45° Elbow SAE 45° Inverted Flare Swivel

Assembly No. 80

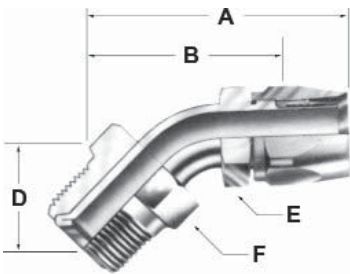

Part Number	Hose Size	Conn Size	Thread NPTF	A	Cut Factor B	Nom ID C	D	Hex E	Hex F
T265-4-4RIM45	4	4	7/16-24	2.47	1.99	0.16	0.94	0.44	0.56
T265-5-5RIM45	5	5	1/2-20	2.45	1.94	0.22	0.94	0.50	0.62
T265-6-5RIM45	6	5	1/2-20	2.49	1.96	0.28	0.94	0.50	0.69
T265-6-6RIM45	6	6	5/8-18	2.50	1.96	0.28	0.94	0.62	0.69
T265-8-8RIM45	8	8	3/4-18	2.70	2.04	0.38	0.94	0.75	0.81
T265-10-10RIM45	10	10	7/8-18	2.95	2.28	0.46	1.02	0.88	0.94
T265-12-12RIM45	12	12	1 1/16-16	3.12	2.46	0.58	1.02	1.06	1.12

90° Elbow SAE 45° Inverted Flare Swivel

Assembly No. 81

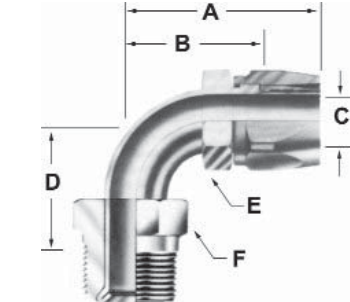

Part Number	Hose Size	Conn Size	Thread NPTF	A	Cut Factor B	Nom ID C	D	Hex E	Hex F
T265-4-4RIM90	4	4	7/16-24	2.04	1.57	0.16	1.65	0.44	0.56
T265-5-5RIM90	5	5	1/2-20	2.08	1.57	0.22	1.64	0.50	0.62
T265-6-5RIM90	6	5	1/2-20	2.12	1.60	0.28	1.65	0.50	0.69
T265-6-6RIM90	6	6	5/8-18	2.12	1.60	0.28	1.69	0.62	0.69
T265-8-8RIM90	8	8	3/4-18	2.32	1.69	0.38	1.78	0.75	0.81
T265-10-10RIM90	10	10	7/8-18	2.66	1.99	0.46	2.17	0.88	0.94
T265-12-12RIM90	12	12	1 1/16-16	2.83	2.17	0.58	2.17	1.06	1.12

2 Hole Swivel Flange

Assembly No. 82

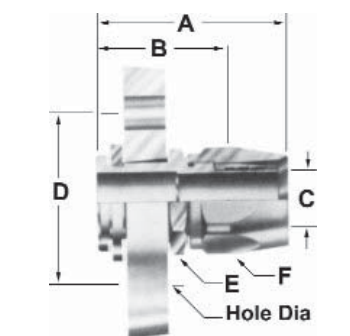

Part Number	Hose Size	Conn Size	Flange	A	Cut Factor B	Nom ID C	D	Hex E	Hex F
T250-6-12RFL	6	12	2 7/8-1 21/32	1.78	1.26	0.28	0.44	1.00	0.69
T250-12-12RFL	12	12	2 7/8-1 21/32	2.08	1.42	0.56	0.44	1.06	1.12



Quick Couplings

Total Quality Control



Thorburn's CNC lathe technology provides unparalleled manufacturing quality.

- ISO 9001 registered quality assurance program
- Materials: ASME Section II

In-House Product Development & Testing



- Leak & destructive testing up to 150,000 psi
- Impulse testing up to 10,000 psi @ 400°F
- Flex & seismic testing



Thorburn's commitment to development is reinforced through the use of CAD (Computer Aided Design) system technology and finite engineering analysis, which permits us to pinpoint potential critical areas and provide sound engineered solutions.

STRAIGHT-THROUGH

- Sizes 1/4" to 2".
- Proven ball-lock mechanism provides positive connections.
- Sockets and plugs interchangeable with other manufacturers that conform to ISO 7241 Series B couplings such as Hansen ST Straight-Through Series
- Thorburn's NT82 series can be designed, manufactured and registered to ASME B31.1, and ASME Section III, class I, II or III services.
- Standard material - Brass (ASTM B16/B21)
Stainless Steel springs balls and retaining rings

THORBURN NT82 SERIES

Quality you can depend on!

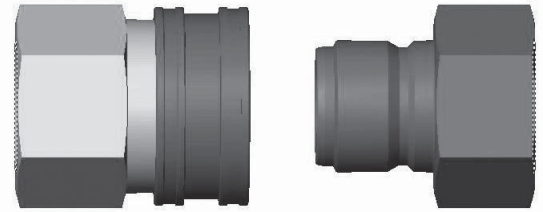

Dimensional Information

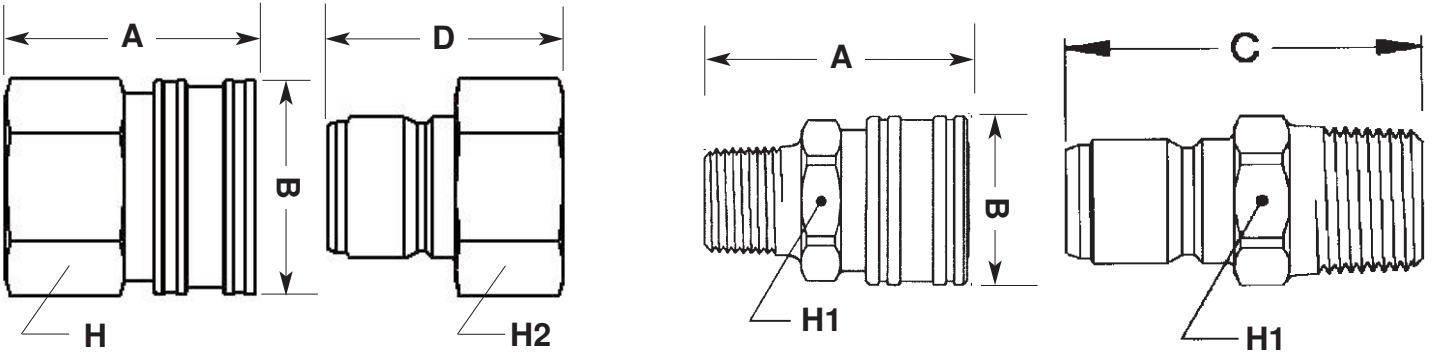

SIZE	COUPLER			PLUG				PRESSURE RATING (PSI)			
	A	B	H	MPT		FPT		BRASS		SS 316	
				C	H1	D	H2	DESIGN	PROOF	DESIGN	PROOF
1/4	1.50	0.94	0.81	1.50	0.62	0.65	0.68	3700	16650	4000	18000
3/8	1.59	1.13	1.00	1.63	0.68	1.69	0.81	1950	8775	3500	15750
1/2	1.92	1.30	1.12	1.88	0.88	2.03	1	1600	7200	2000	9000
3/4	2.06	1.63	1.50	2.00	1.12	2.25	1.12	1250	5625	1250	5625
1	2.33	1.99	1.75	2.18	1.38	2.53	1.62	1000	4500	1250	5625
1 1/4	2.44	2.50	2.00	2.34	1.75	2.72	2	1000	4500	1000	4500
1 1/2	2.88	3.12	2.62	2.88	2.25	3.31	2.25	1000	4500	1000	4500
2	3.08	3.74	3.00	3.25	2.75	3.50	2.75	1000	4500	1000	4500

Note:
Proof pressures listed were taken at the point at which failure made the coupling inoperative. Burst pressure is 5 times design.

WARNING:
Over-pressurization could result in a sudden failure of the coupling, causing severe bodily injury or death. Be sure to select the proper coupling for your application and use it only within the specified service pressure range.

HOW TO ORDER

Type	Material	Coupling Half	Size	End Fitting Type	Seal	Options
NT82	C=Carbon Steel B=Brass S4=Stainless Steel 304 S6=Stainless Steel 316	C=Coupler N=Nipple DP=Dust Plug DC=Dust Cap	06= 3/8" 08=1/2" 12=3/4" 16=1"	FP=Female NPT MP= Male NPT	V= Viton B=Buna N E=EPDM	SL=Sleeve Lock

DPP: Dust Plug



DC: Dust Cap



Flow Charts

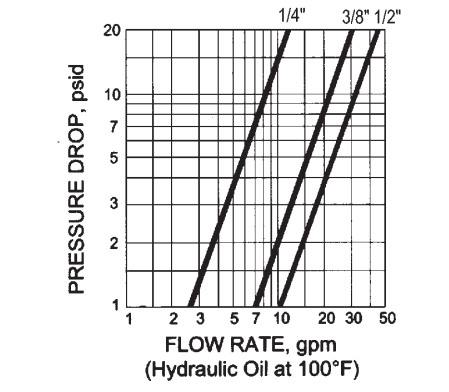
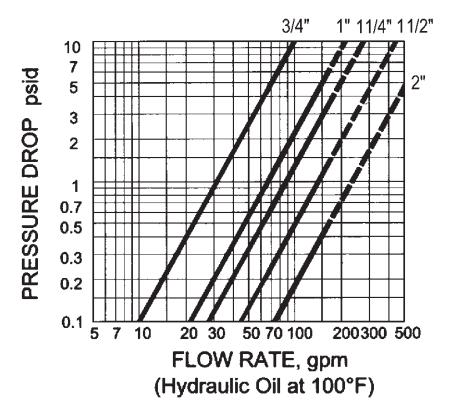

ISO Series A Interchange

- Designed to meet or exceed ISO 7241-1 Series A
- 4-1 safety Factor
- Proven ball-lock mechanism provides positive connection
- Poppet style shut-off
- Interchangeable with other manufacturers that conform to ISO 7241-1A

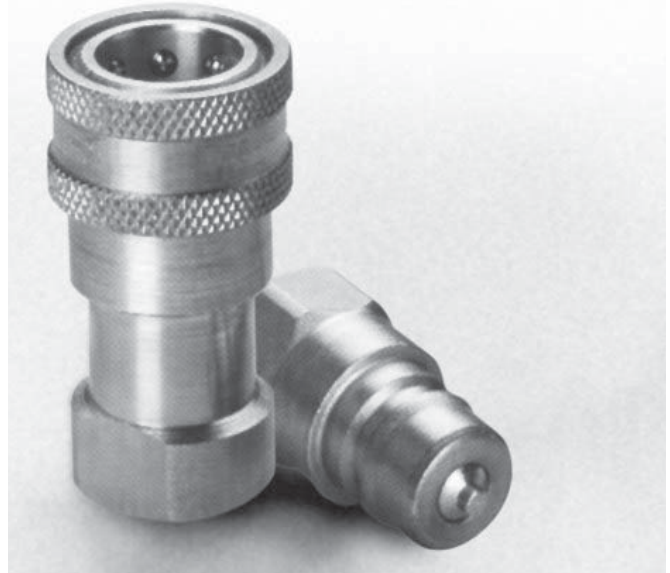

Flow Chart

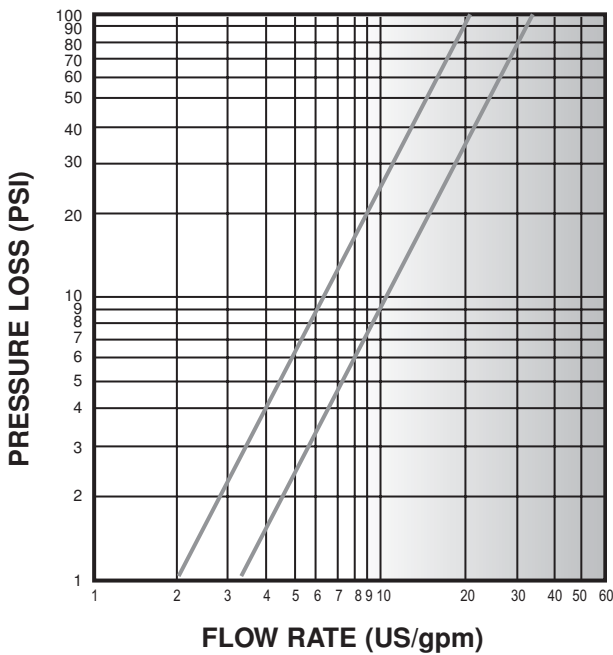

Pressure Ratings

Size	Design Pressure psi	Minimum Burst psi	Maximum Connect by Hand
3/8"	4600	18400	150
1/2"	4000	16000	100

Note: Burst pressures listed were taken at the point at which failure made the coupling inoperative. Burst pressure is 4 times design. Proof pressure is 2 times design and test pressure is 1-1/2 times design.

HOW TO ORDER

The example shown here: **Series T61 Coupler with 3/4" threads with a Female NPT end and Buna N seal.**

All fittings are carbon steel with corrosion-resistant plating

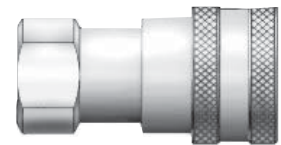

Dimensional Information

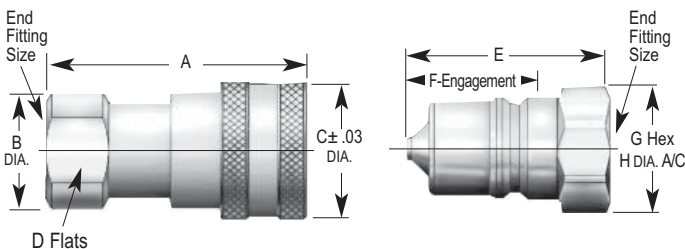

Size	A	B	C	D	E	F	G	H
1/4"	2.32	0.88	1.18	0.75	1.58	1.02	0.75	0.83
3/8"	2.65	1.13	1.37	1.00	1.80	1.24	0.88	0.96
1/2"	3.03	1.38	1.75	1.25	2.10	1.34	1.13	1.24
3/4"	3.61	1.75	2.12	1.50	2.47	1.79	1.38	1.51
1"	4.26	2.00	2.50	1.75	2.93	2.04	1.63	1.79

Type	Material	Coupling Half	Size	End Fitting Type	Seal	Options
T61	C=Carbon Steel B=Brass S6=Stainless Steel 316	C=Coupler N=Nipple	04= 1/4" 06=3/8" 08=1/2" 12=3/4" 16=1"	FP=Female NPT MP= Male NPT	V= Viton B=Buna N E=EPDM	SL=Sleeve Lock

ACCESSORIES

Dust Plugs
T61DP



Dust Caps
T61DC



	Dust Plug	Dust Cap
3/4"	T61-DP6	T61-DC6
1/2"	T61-DP8	T61-DC8

ISO Series B Interchange

- Designed to meet or exceed ISO 7241 Series B.
- Sizes 1/4" to 2" for Brass, Steel & 316SS stainless steel material.
- Proven ball-lock mechanism provides positive connections.
- Poppet style double shut-off.
- Sockets and plugs interchangeable with other manufacturers that conform to ISO 7241 Series B couplings (including Hansen HK series two way shutoff).
- Thorburn's NT72 series can be designed, manufactured and registered (c/w CRN) to ASME B31.1, CSA B51.

THORBURN NT 72 SERIES Quality you can depend on!

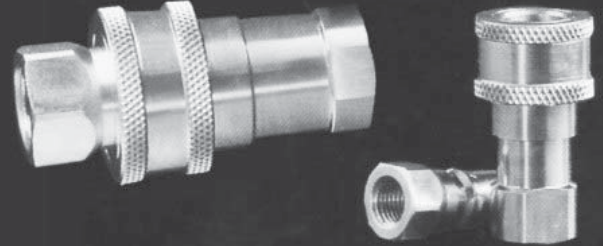

Flow Chart

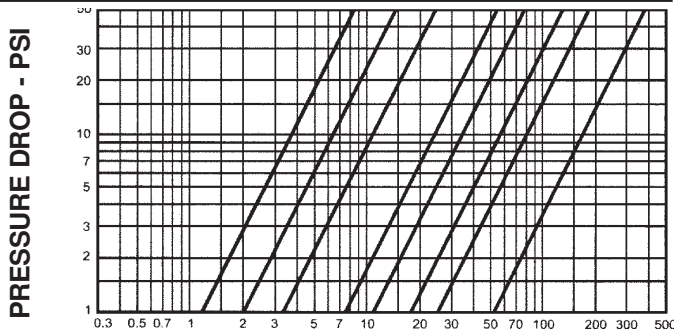

FLOW RATE (US/gpm) – HYDRAULIC OIL AT 100°F

Flow Capabilities

Series	C _V	C _V Less Valves	C _V With Valve Actuator	A _C	A _C Less Valves	A _C With Valve Actuator
NT72-04	1.1	2.2	1.0	28	55	25
NT72-06	1.9	4.0	1.8	48	100	45
NT72-08	3.2	7.6	3.1	80	190	78
NT72-12	8.2	21.0	8.2	205	525	205
NT72-16	11.4	36.0	11.5	285	900	288
NT72-20	16.9	69.9	24.5	422	1748	612
NT72-24	24.0	119.0	35.0	600	2980	875
NT72-32	50.0	232.0	76.0	1250	5800	1900

Dimensional Information

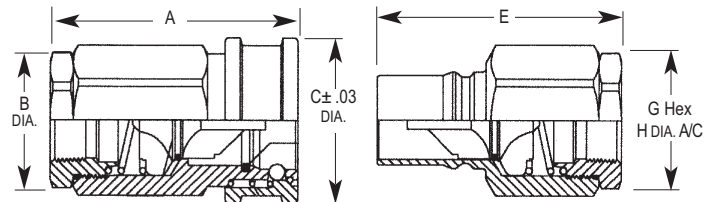
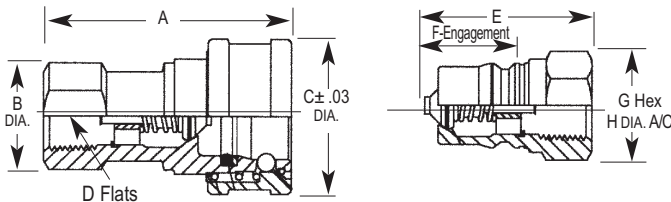

Size	A	B	C	D	E	F	G	H
1/4"	2.26	0.88	1.17	0.75	1.52	1.02	0.87	0.75
3/8"	2.56	1.00	1.42	1.00	1.76	1.24	1.01	0.88
1/2"	2.96	1.28	1.86	1.25	2.03	1.34	1.30	1.13
3/4"	3.48	1.56	2.22	1.50	2.36	1.79	1.52	1.31
1"	4.13	1.86	2.61	1.75	2.84	2.04	1.88	1.63

Size	A	B	C	E	G	H
1 1/4"	4.51	2.38	2.73	4.25	2.73	2.38
1 1/2"	4.82	2.38	3.23	4.76	3.02	2.38
2"	5.56	3.75	4.11	5.49	4.31	3.75

Pressure Ratings

Size	Stainless Steel 316SS		Brass	
	Design psi	Burst psi	Design psi	Burst psi
1/4"	4200	18900	2000	9000
3/8"	4200	18900	1500	6750
1/2"	3500	15750	1500	6750
3/4"	3500	15750	1500	6750
1"	2200	9900	1000	4500
1 1/4"	1300	5850	500	2250
1 1/2"	1300	5850	500	2250
2"	1300	5850	500	2250

Note: Burst pressures listed were taken at the point at which failure made the coupling inoperative. Burst pressure is 4 times design.

HOW TO ORDER

The example shown here:
Series NT72 Coupler with a 3/4" Female NPT end in 316SS with Buna N seal.

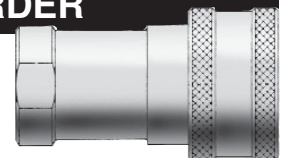

Type	Material	Coupling Half	Size	End Fitting Type	Seal	Options
NT72	CS = Carbon Plate Steel S6 = Stainless Steel 316 B = Brass	C = Coupler N = Nipple DP = Dust Plug DC = Dust Cap	04 = 1/4" 06 = 3/8" 08 = 1/2" 12 = 3/4" 16 = 1" 20 = 1 1/4" 24 = 1 1/2" 32 = 2"	FP = Female NPT XX = Special End	V = Viton B = Buna N E = EPDM	SL = Sleeve Lock

T71 Series: Flush Face/Dry Break Couplings

- **Flush Face/Dry Break** – Air inclusion and fluid loss are held to a minimum to prevent spillage and contamination of systems
- **Push-to-Connect** – Ideal on-hand operation when one half is mounted. Simply insert the nipple into the coupler and push-to-connect. To disconnect, retract the sleeve; and the coupling halves disconnect.
- **Rugged** – Heavy duty construction is ideally suited for high impulse applications.
- **Pressure Capability** – Designed for up to 3000 psi operating pressures.
- **Versatile** – Available in 316 stainless steel, carbon steel and other materials. Special seals for troublesome media are available; consult Thorburn for details.
- **Available sizes** – 1/4", 3/8", 1/2", 3/4", 1", 1 1/2", 2".
- **Superior flow and low pressure drop.**
- **Sleeve lock** – Designed to provide protection against accidental disconnection.



Flow Pressure Drop

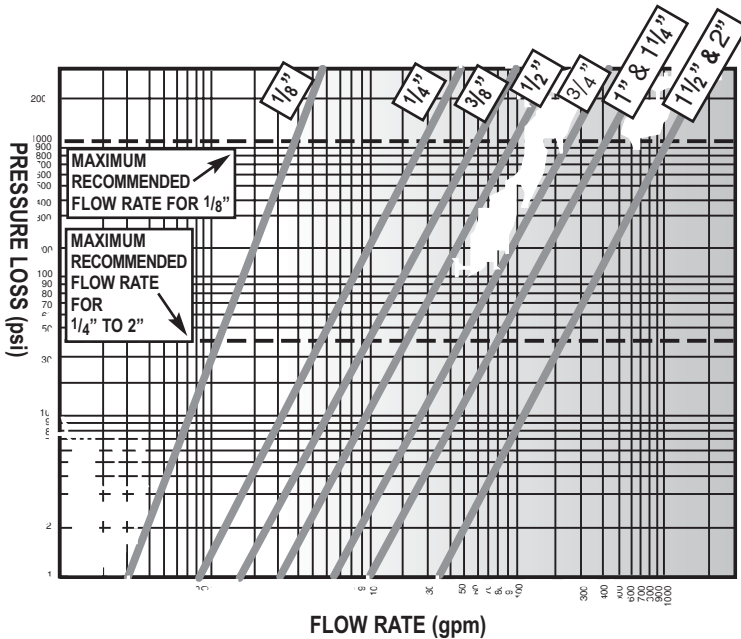

SPILLAGE, AIR INCLUSION, PRESSURE RATINGS

Size (in.)	Spillage (cc)	Air Inclusion (cc)	Max. Working pressure psi	Min. Burst* pressure psi
1/8"	.12	0.02	3000	12500
1/4"	.01	0.005	3000	12500
3/8"	.07	0.05	3000	12500
1/2"	.09	0.11	3000	12500
3/4"	.10	0.13	3000	12500
1"	.20	0.40	2500	10000
1 1/4"	.20	0.40	2500	10000
1 1/2"	5.25	30.50	1500	6000
2"	5.25	30.50	1500	6000

Note: Burst pressures listed were taken at the point at which failure made the coupling inoperative. Burst pressure is 4 times design. Proof pressure is 2 times design and test pressure is 1-1/2 times design.

Dimensional Information

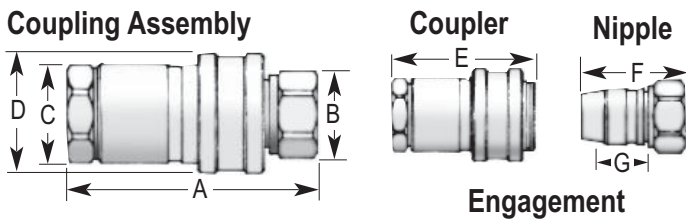

Size	A	B(Hex)*	C(Hex)*	D(Dia.)	E	F	G
1/8"	2.71	.69	.81	.94	1.75	1.55	.59
1/4"	3.27	.81	.94	1.19	1.96	1.84	.53
3/8"	4.00	1.00	1.19	1.56	2.36	2.32	.68
1/2"	4.43	1.50	1.50	1.88	2.77	2.38	.72
3/4"	5.13	1.75	1.75	2.25	3.05	2.96	.88
1"	5.60	1.88	2.25	2.63	3.32	3.23	.95
1 1/4"	6.22	2.00	2.25	2.63	3.67	3.50	.95
1 1/2"	7.60	3.25	3.38	4.50	6.21	4.50	3.21
2"	7.60	3.25	3.38	4.50	6.21	4.50	3.21

* Hex dimensions are taken from flat or hex and not across corners.
Note: Dimensions are for reference only and are subject to change without notice.

HOW TO ORDER THORBURN T71 SERIES

The example shown here:
Stainless Steel Series T71 Coupler with 3/8" threads with Female NPT end with EPDM seal.



T71	S6	N	8	MP	V	SL
Series	Materials	Coupling Half	Coupling Size	End Fitting	Seals	Options
T71	Standard material 316SS S6=316 C= Carbon	C=Coupler N=Nipple	2 = 1/8" 4 = 1/4" 6 = 3/8" 8 = 1/2" 12 = 3/4" 16 = 1" 20 = 1 1/8" 24 = 1 1/2" 32 = 2"	FP= Female NPTF MP= Male NPT TC= Swage Lok compatible nut and sleeves 1/4" size only	B = Buna V = Viton* E = EPDM <small>*Trademark of Dupont</small>	SL = Sleeve Lock

T75 Series: High Pressure Couplings

Dependabilities at high pressures. Heavy duty.

Thorburn T75 high pressure couplings are designed for rugged hydrostatic drive applications in the mining and oil industries.

DESIGN FEATURES

- **Excellent flow characteristics** for continuous duty application. See flow chart.
- **High strength steel poppet guides** prevent breakup and washout of coupling valving during high surge and shock conditions.
- **Exclusive four point support design of poppet guide** provides positive alignment of valving during high surging flow conditions.
- **Flat crested stub-acme threads and all steel construction** withstand storage and rig-up damage.
- **Protective treatment** equal to industry standards for SAE steel hose fittings.
- **Structurally compatible** with weight of 5,000 psi flex-hose and system induced shockloads.

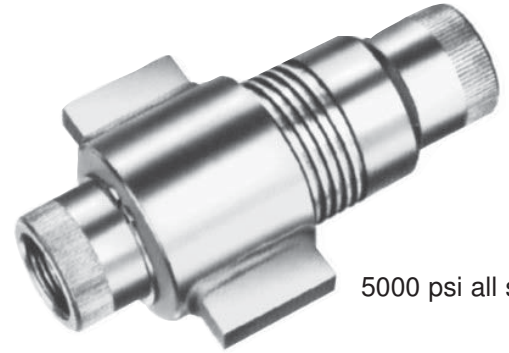

5000 psi all sizes

OPERATING LIMITS

- **5,000 psi operating pressure**— all sizes
- **20,000 psi minimum burst**— coupled
- **Vacuum to 28" Hg**
- **Standard seal**— temperature range -65°F to +250°F
- **Buna-N seals**— standard

Pressure Drop vs. Flow (USGPM) - Coupling

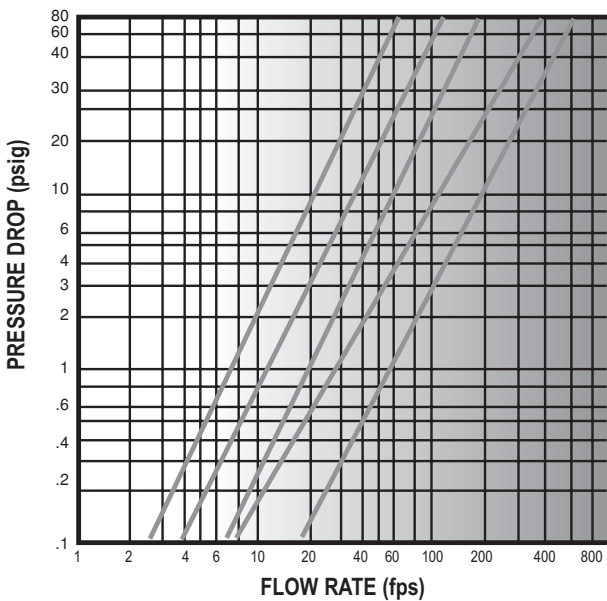

SPILLAGE & AIR INCLUSION (at 0 psig)

Size	3/4"	1"	1 1/4"	1 1/2"	2"
Spillage (cc)	8	16	31	64	141
Air Inclusion (cc)	12	25	48	98	205

HOW TO ORDER

The example shown here:
Carbon Steel Series T75
Coupler with 3/4" threads with a Female NPT end with Buna N seal and a sleeve lock.

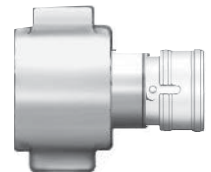

Type	Material	Coupling Half	Size	End Fitting Type	Seal	Options
T75	Standard material carbon steel C= Carbon steel S6=316SS	C=Coupler N=Nipple DP=Dust Plug DC=Dust Cap	12 = 3/4" 16 = 1" 20 = 1 1/4" 24 = 1 1/2" 32 = 2"	Standard is FP FP = Female NPTF MP=Male NPT MJ=Male 37° FL= Code 61 Flange	B=Buna V=Viton* E=EPDM	SL = Sleeve Lock

Special Note: Nominal hose & coupling sizes listed in 1/16";
 i.e. 12 = 3/4", 6 = 3/8", etc.

Dimensional Information

Coupling Assembly

Nipple

Coupler

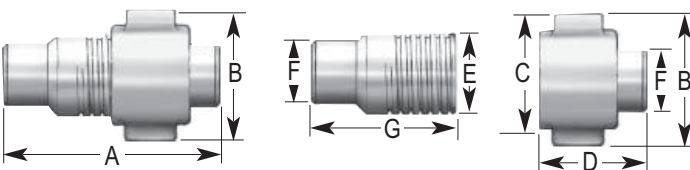

Size	A	B	C (Dia)	D	E (Dia.)	F	G	Acme H
3/4"	4.85	—	1.87	2.84	1.75	1.35	3.27	1 3/4"-8
1"	6.04	4.25	2.75	3.45	2.25	1.77	4.17	2 1/4"-6
1 1/4"	7.76	4.75	3.25	4.40	2.62	2.14	5.36	2 5/8"-6
1 1/2"	8.70	5.75	3.75	5.04	3.24	2.50	5.97	3 1/4"-4
2"	10.05	6.75	4.75	6.07	4.00	3.25	7.05	4"-4

Aluminium dust caps

THA-DC

Aluminium dust plugs

THA-DP

Plastic caps

THP-DC

Plastic plugs

THP-DP



Sizes 1/4" to 1"



Sizes 1/4" to 2"

THORBURN

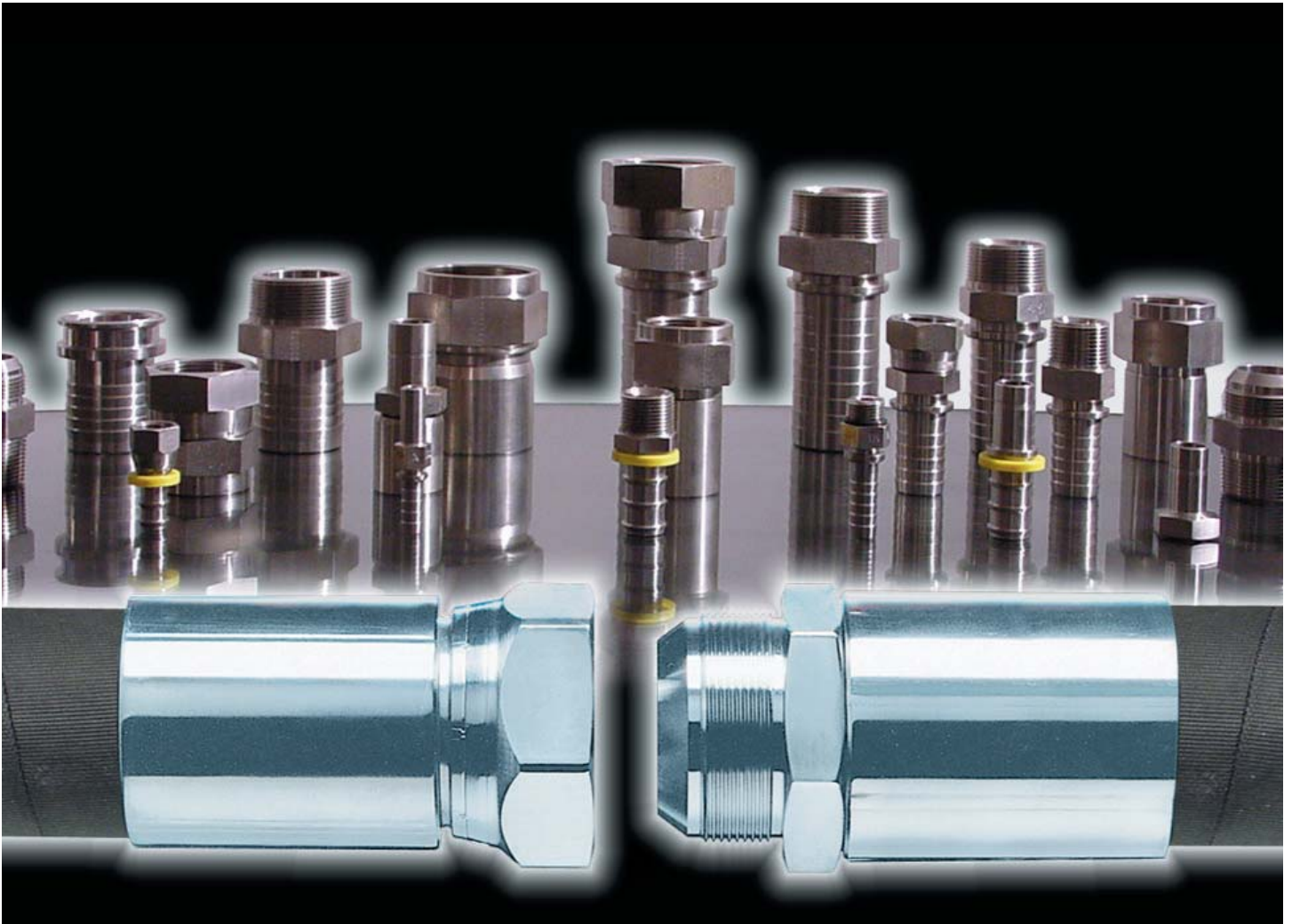

THORBURN'S WARRANTY

Thorburn warrants its products to be free from any defects of workmanship and material. Thorburn's warranty shall only cover the components of such assemblies manufactured by Thorburn. Should any such defects be discovered within three (3) months from the date of purchase by the end user, the questionable part should be returned to Thorburn. If, upon inspection, the part proves to be defective, Thorburn will furnish a replacement, or, at its option, repair the part.

This warranty shall not apply to any part or parts of hose products if it has been installed, altered, repaired or mis-used, through negligence or otherwise, in a way that in the opinion of Thorburn affects the reliability of, or detracts from, the performance of the product. Nor does this warranty cover replacements or repairs necessitated by loss of damage resulting from any cause beyond the control of

Thorburn, including but not limited to acts of God, acts of government, floods and fires.

The obligation of Thorburn under this warranty is limited to making a replacement part available or the repair of the defective part, and does not include the furnishing of any labor involved or connected therewith, such as that required to diagnose trouble or to remove or install any such product, nor does it include responsibility for any transportation expenses or any damages or losses incurred in transportation in connection therewith.

The foregoing is in lieu of any other warranties, expressed, implied or statutory, and Thorburn neither assumes nor authorizes any person to assume for Thorburn any other obligation or liability in connection with the sale of its products.

"O" SEAL HOSE COUPLINGS

No more leaks with Thorburn 316SS O-Seal™ technology

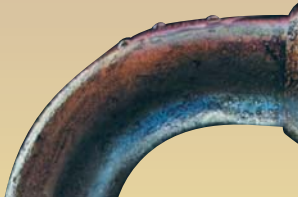

JIC 37° Removal



Coupling must be moved away from adapter.



"O" SEAL TECHNOLOGY

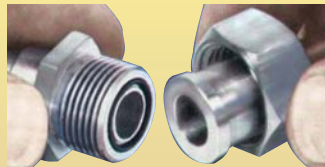

"O" Seal Removal

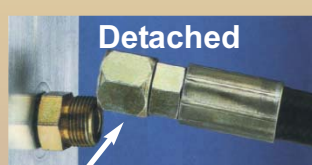
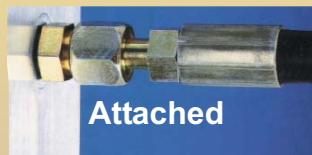

Retractable nut pushes back and coupling can be moved to the side

FEATURES

- Sizes 1/8" to 2"
- Design pressures vacuum to 6000 psi
- Materials: SA182/SA479 type 316

THORBURN is a world leader in the design and manufacture of stainless steel hose couplings.

Design pressures to 6,000 psi
Sizes 1/8" to 2" ID



In-house design, manufacturing and testing capabilities.



*Impulse testing up to 10,000 psi.
Burst testing up to 150,000 psi.*

THORCRIMP BENEFITS

- 360° blow-off proof crimp, better holding power and reliability.
- Smaller finished crimp; streamlined assemblies.
- High flow orifice, low pressure drop.



*In-house crimping.
1/8" to 3" pipe size.*

THORBURN adapters make connections easy!



Thorburn Flex Inc

Flexible Piping Specialist



CALL NOW — LET US HELP YOU!

**MONTREAL HEAD OFFICE
MARITIMES / WESTERN CANADA
THORBURN FLEX INC.**

Manufacturing Division
173 Oneida Drive
Pointe-Claire, Quebec, Canada H9R 1A9
Tel.: (514) 695-8710 Fax: (514) 695-1321

**UNITED STATES
THORBURN FLEX INC.**

151 New Park Avenue
Hartford, Connecticut, USA 06106
Tel.: 1-800-363-6613
Fax: (514) 695-8716

**TORONTO / ONTARIO
THORBURN FLEX INC.**

49-6A The Donway West, Suite 815
Don Mills, Ontario M3C 2E8
Tel.: (905) 715-7013
Fax: (905) 715-7816

Toll free: 1-800-363-6613